

## CHAPTER 5

---

# EXPERIMENTAL AND OBSERVATIONAL PROOF OF THE ETHER

---

Chapter 5 is divided into seven subdivisions.

- 5.1 Introduction
- 5.2 The Inflow of the Accelerating Ether
  - 5.2.1 The Moon Io
  - 5.2.2 The Pendulum Drive is Superior to the Kinetic Drive
  - 5.2.3 The Rotating Wheel with Buckets and Pistons
  - 5.2.4 The Ferris Wheel
- 5.3 The Homopolar Generator and Homopolar Motor
  - 5.3.1 The Homopolar Generator
  - 5.3.2 The Homopolar Motor
- 5.4 Electromagnetic Propulsion without a Propellant
  - 5.4.1 Propulsion from the Rectangle.
  - 5.4.2 Propulsion of the Railgun; a Hypothetical Presentation of the Theory
  - 5.4.3 Propulsion of the Railgun; a Practical Device
  - 5.4.4 Propulsion of the Ring
- 5.5 The Permanent Magnetic Motors
  - 5.5.1 The Merging of Electromagnetism with Permanent Magnetism
  - 5.5.2 The Circular Permanent Magnetic Motor
  - 5.5.3 The Shielded Permanent Magnetic Motor
- 5.6 Gyroscopes as a Function of PFGRT
- 5.7 Conclusion

### 5.1 Introduction

Presuming **the ether** exists, then the entire macro/micro universe is a function of that ether. And if so, then by logic, modern-day physics, including the irrefutable laws of physics, must be totally revised, moreover, rewritten.

In order to have any credibility, all accepted theories require confirmation/validation by experimental and/or observational evidence. Otherwise, they remain only theories, and over time they fade from human consciousness. Listed below in sections 5.2 through 5.7 are the evidence/observations confirming the reality of the ether.

## 5.2 The Inflow of the Accelerating Ether

- 5.2.1 The Moon Io
- 5.2.2 The Pendulum Drive is Superior to the Kinetic Drive
- 5.2.3 The Rotating Wheel with Buckets and Pistons
- 5.2.4 The Ferris Wheel

### 5.2.1 The Moon Io

See Figure 5.1. Recall Io is the closest moon to Jupiter. The inflowing ether (PFGRT), or articulated in classic terminology, the gravitational field produced by Jupiter, is angled inwards towards its own central mass. Therefore, as Io orbits Jupiter, then between perigee and apogee, this function sequentially and continually squeezes, as well as stretches, that moon then defined as tidal forces. This effect produces heat from internal friction, and in turn, on Io, continuous volcanic activity.

---

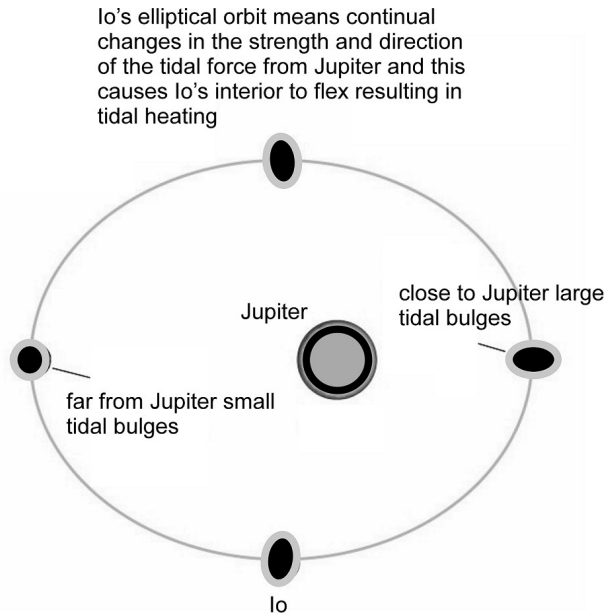

**Figure 5.1** Io Orbiting Jupiter

---

The question is: From where does the energy that produces that volcanic activity ultimately originate? If one acknowledges the classic law of conservation of energy as valid, then it must be borrowed from somewhere. Notice, with the use of the classic laws of physics, it is not really apparent from where.

In other words, while orbiting between perigee to apogee, if Io's volcanic activity (force/energy) is ultimately a function of differential geodesic motion (inertial) from one of its sides compared its other side (4D-ST), then in order to be compatible with the law of conservation of energy, where does the force/energy come from? Again, it must be borrowed from somewhere, but where?

Viewed from another perspective, if the volcanic activity on Io represents a gain of energy, then by what mechanism does curved space-time (4D-ST) give up that same amount of energy? It is not as obvious as how.

Alternatively, if one presupposes the inflowing ether theory, somewhat analogous to how water flows into a sink or from a dam, there is a continuous, moreover, endless resupply of **accelerating** inflowing space. As a result, there is unlimited energy for the production of tidal forces, friction, heat, and ultimately, volcanic activity.

In the literature, with reference to Jupiter and its orbiting moons, other theories are posited, such as multiple, competing, and interacting gravitational forces, generating resonance. However, if this postulate were true, then the orbital radial of the interacting moons should decay over time, for a gain, energy must be borrowed from somewhere. If so, then over the time span of billions of years, one would expect that the inner moons would fall into Jupiter, thus cease to exist. But no orbital decay of Io has ever been observed. Even so, these alternate theories are still possible. Regardless, the crucial concept to recognize is this: the **Inflowing Ether Theory (PFGRT)** can also account for the production of Io's tidal forces, with its associated volcanic activity.

As a corollary, furthermore, to some extent comparable to the above example, Jupiter self illuminates. It is brighter than expected presupposing that the light from Jupiter observed by astronomers represents only the Sun's reflected light. If one quotes the literature, supposedly, this extra brightness is a product of Jupiter's gravitational field. Basically, the gravitational field causes the planet to very gradually shrink over time (eons), thereby generating excess light. In addition, other concepts are posited such as low-level nuclear reactions. Nevertheless, this contraction has not been confirmed; furthermore, none of the other theories have ever been substantiated.

Alternatively, if one presumes a continuous inflow of space (ether) into Jupiter (PFGRT), then the excess light could be a product of that inflow. Again, as hypothesized in the example of Io, PFGRT is only one of the theoretical possibilities.

## 5.2.2 The Pendulum Drive is Superior to the Kinetic Drive

*Potential Energy to Kinetic Energy, Veljko Milkovic.*

Please refer to this website:

<https://www.youtube.com/watch?v=N-JKa4Bexz0>

To begin, please refer to the website video as shown. Take note, in order to understand this experiment, it is much easier to observe it on video rather than imagine it from a detailed written description.

The above YouTube video demonstrates that a pendulum drive (PD) is highly superior to a kinetic energy drive (KD). The outcome of this experiment is self-evident. Nevertheless, it is inexplicable, vis-à-vis accepted laws of modern physics.

The following two figures, 5.2 and 5.3, are representative of that YouTube video. Please now review those two figures. Each is followed by a discussion. Notice, relevant to figures 5.2 and 5.3, the distance (D = black arrow length) traveled by the PD is significantly greater compared to that of the KD.

Considering modern physics, theoretically, in order to propel the cart forward, the only energy available for both experiments (KD and PD) is approximately the same amount of gravitational potential energy (GPE), because both experiments initiate their "fall of the ball" vs. the "pendulum motion" at the same height above the Earth. Nevertheless, the cart travels a significantly greater distance using the PD compared to the KD (three times as far).

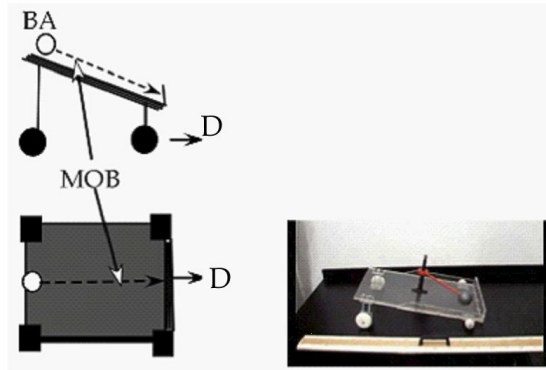

Viljko Milkovic

**Figure 5.2** Kinetic Drive (KD) [Fair Use]

- *BA = ball*
- *MOB = motion of ball*
- *D = distance = length of arrow = distance traveled*

The ball (BA) "falls" on the angled platform, moreover, strikes its base, located at the bottom. This is a onetime event. Therefore, as a function of this single occurrence, forward propulsion from force is exerted on the cart. As such, the cart travels a given distance, denoted by the black arrow labeled D. Take note: the kinetic drive (KD) distance traveled is significantly less in Figure 5.2 compared to the pendulum drive (PD) distance, the latter shown below in Figure 5.3.

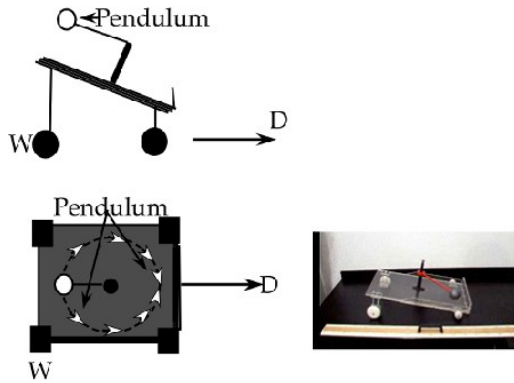

Viljko Milkovic

**Figure 5.3** Pendulum Drive (PD) [Fair Use]

- *P = pendulum*
- *M = pendulum motion*
- *W = wheel*
- *D = distance is length of arrow = distance traveled*
- *MOB = pendulum motion of ball*

*The pendulum with the same ball swings (falls) back and forth numerous times. And for each and every occasion, there is forward propulsion from force exerted on the cart. As a result, the cart travels a given distance represented by the length of the straight black arrow labeled D. The total distance traveled as a function the PD (Figure 5.3) is significantly greater compared to the kinetic drive (KD) distance (D), the latter as shown in Figure 5.2.*

In addition, the PD must be that of over unity. The rationale for why is as follows, vis-à-vis both experiments: (GPE) is converted into the kinetic energy (KE), which is what is used to propel the cart forward. So again, regarding both scenarios, given that the ball-(KD) and pendulum-(PD) initiate their "fall" at the same height above the Earth's surface, then the maximum GPE available for conversion to KE is identical. Nevertheless, the PD travels a significantly greater distance compared to the KD, in fact, is three times as far.

Referring to the PD, as the pendulum swings back and forth, GPE is converted into KE and then taken back, moreover, a gain converted to KE and once again taken back, and so on and so forth. Observe, each time the cart moves forward, as a function of the pendulum's back-and-forth oscillation, it then loses some of its original height above the Earth until it eventually stops. In contrast, with reference to the KD, this is a one-time event.

Here is the crucial concept to acknowledge: this one-time (KD) event represents the conversion of the maximum available GPE into the maximum possible KE. In effect, there is no other energy accessible. Consequently, by logic, the maximum KE obtained by the KD cannot exceed the maximum GPE available. So, common sense tells us that the excess work (force x distance) associated with the PD must be that of over unity.

This comparative analysis may not be totally germane, and here is the reasoning why. The same ball (inertial mass) is used for both demonstrations. Nevertheless, the bar-segment of the pendulum possesses its own separate inertial mass. Consequently, the mass/shape of the ball differs slightly compared to the overall mass/shape of the pendulum. However, the difference is not enough to account for the disparity of the distances traveled by the two different experiments.

This concept is somewhat abstract, so for review, here is another explanation. Let us assume, regarding these two experiments, that they are absolutely frictionless. Additionally, presume no air resistance. Therefore, with reference to the KD, as the ball strikes the platform's base, there is a one-time pulse of acceleration, producing momentum (velocity), which is KE.

Alternatively, regarding the PD, for each and every time the pendulum swings back and forth, there is a pulse of acceleration exerted on the cart. So, ultimately, these sequential series of propulsions result in a greater velocity (KE = momentum) when compared to the KD. The final KE (velocity) associated with the PD is considerably greater than the final KE associated with the KD. Yet the maximum kinetic energy possible, as a product GPE, can only be equal to that of the KD.

That is to say, for each time the pendulum swings back and forth, it propels the cart forward. However, this forward motion (KE) then causes the pendulum to lose some of its original upward height (GPE). So, after the swing, its height above the Earth is not as high as before the swing. The forward propelling motion (KE) of the cart borrows some of the energy from the swinging motion of the pendulum (GPE). As a result, as the pendulum swings back and forth, its amplitude progressively decreases until it terminates, at which time, the successive series of forward impulses from propulsion exerted on the cart then also ceases.

Again, there is a slight difference in the mass/shape of the ball versus pendulum, although not enough to account for the difference in the magnitude of the final KE between the two experiments. Basically, the PD outcome (3 times the distance of the KD) is not possible presuming the laws of modern physics are valid. However, it can be explained by utilizing the

concept of the accelerating factor of the **inflowing space/ether (PFGRT)**, somewhat analogous to work ( $W = F \times D$ ) performed as a function of water falling from a dam.

The outcome of this experiment is of great practical value. For instance, this concept has already been incorporated into other Milkovic inventions, such as the pendulum water pump, as well as the two-stage mechanical oscillator pendulum-lever system, as found on Veljko Milkovic's YouTube channel. Of particular interest is a gain in the video "Superiority of Pendulum Drive—Potential Energy to Kinetic Energy."

Technical drawings are also available on this site. After reviewing this YouTube clip, you should find it obvious that these inventions are truly over unity devices. Shown below in figures 5.4 and 5.5 are schematics of two such devices.

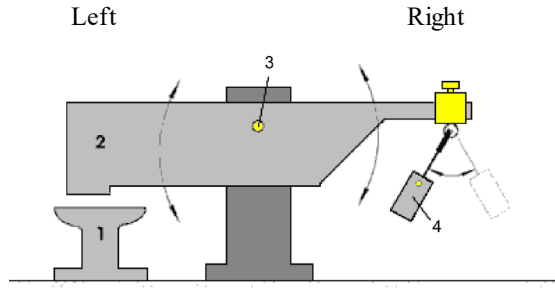

<https://www.veljkomilkovic.com/rucnaPumpaEng.html>

**Figure 5.4** Pendulum Drive (PD) with Up/Down Motion [Fair Use]

- The pendulum (4) swings back and forth relative to its pivot (right).
- This produces, with respect to the fulcrum (3), an oscillating up and down motion of 2 relative to 1 (left).

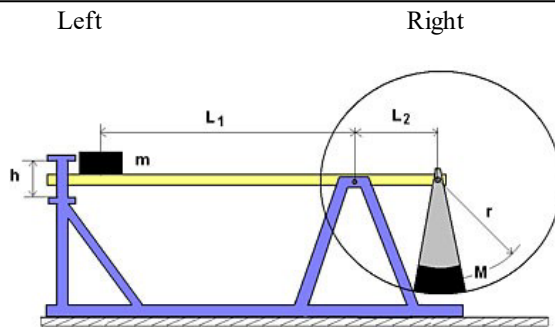

<https://www.veljkomilkovic.com/rucnaPumpaEng.html>

**Figure 5.5** Pendulum Drive (PD) with Horizontal Motion [Fair Use]

On the right, relative to its pivot as the pendulum swings back and forth, it produces, as a function of the fulcrum, an up and down oscillation of the black box (m) depicted on the left. The fundamental concept to appreciate is that the amount of input work needed to maintain the motion of the swinging pendulum is considerably less compared to the output work of the oscillating m.  $Work = force \times distance$ .

In addition, the two photos pictured below are of pendulum water pumps, which again appear to function as over unity devices.

---



Veljko Milkovic - <https://www.veljkomilkovic.com/rucnaPumpaEng.html>

**Figure 5.6** Photo of Water Pump with Pendulum Drive (PD) [Fair Use]

*This is a photo of the ultra efficient pendulum pump prototype made in Novi Sad in 2012 by PC Panex Ltd. with financial support from the Serbian Ministry of Education, Science and Technological Development and Provincial Secretariat for Economy, Employment, and Gender Equality of the Autonomous Province of Vojvodina, Republic of Serbia. [Source: <http://bit.ly/2aClpsu>]*

---



Gravitational Energy Corp.



Bruce Feltenberger

**Figure 5.7** Photo of Water Pump using Pendulum Drive (PD) and Inventor Bruce Feltenberger [Fair Use]

*Operating the pendulum (the bar in front of the child) is as easy as pushing a child on a swing. It takes a little effort to get it moving, but once in motion, it takes far less effort to keep it swinging. The first advantage of the pendulum design resides in its pivot.*

*By reducing the friction at the pivot point of the pendulum to nearly zero, the pendulum swings very freely and only needs an occasional small input force to maintain its motion. This device is five times more efficient than a hand water pump without a pendulum. Therefore, the operator can pump 1,000 gallons per hour with very little fatigue. www.VeljkoMilkovic.com "Hand Water Pump with a Pendulum"*

At 5 minutes, 24 seconds on the YouTube channel "Water Crisis—A Solution.wmv," you will see how easy it is for the two children to pump 1,000 gallons per hour. The left image in Figure 5.7 above with the children (arrows) and the following caption was also obtained from that Gravitational Energy Corporation website.

Additionally, the following other websites also refer to this revolutionary invention:

1. Apparent, but not acknowledged, over unity is found at 4 minutes, 40 seconds on this YouTube channel, Gravity-Assisted-Power.mp4.
2. Hand water pump with a pendulum: Technical Drawings Dimensions and Weights can be found on Veljko Milkovic's website.
3. Veljko Milkovic's website also demonstrates his invention.
4. What is more, the following website contains a published scientific article relevant to the over unity aspect of the pendulum water pump and the two-stage mechanical oscillator pendulum-lever system. <http://bit.ly/2b4puZ7>

The article's conclusion: "Based on the results obtained after testing the model, it was quite obvious that the amount of energy to be given to the system is less than the amount of energy obtained from the system."

Veljko Milkovic also proclaims that the work output is 12 times the work input. Assuming that Veljko Milkovic's claim is accurate, this invention is simple, practical, and eventually, most likely very profitable. For example, first, all one needs to do is pump water uphill with a work input-to-output ratio of 1 to 12 as stated by Veljko Milkovic. Next, use the GPE of the water to drive a turbine similar to a small power-generating dam. Note, water-generating dams have an efficiency of up to 80 percent. After that, employ a small portion of that electrical power to maintain the pendulum's motion. And finally, make use of the remaining electrical power production for practical work.

In addition, not only one pump could be utilized but thousands might be set in motion with respect to a water-filled dam. Presuming Milkovic's work input-output ratio is correct, this hypothetical power plant should be successful, moreover, practical.

One major benefit of this model is that a dam containing water not only produces energy, it stores it as well. Consequently, batteries are not necessary. Alternatively, in the situation where there is no water (e.g., desert), the pumping action of the device could be used to pressurize air within metal tanks. Later, that compressed air could be employed to drive a turbine, thus producing electricity.

Further, before use, the compressed air within the metal tanks could be heated with the application of solar power. This technique would then intensify the air pressure within the tanks, thereby increasing efficiency. Effectively, where there is gravity (inflow of space), there is also unlimited free clean energy. Now, all we have to do is learn how to use it.

In the author's opinion, if this concept ever comes to fruition, then know this: Veljko Milkovic is one of the greatest inventors to ever walk the face of the Earth.

So, what methodology does modern-day science use in order to explain Veljko Milkovic's pendulum cart experiment, what is more, its derived inventions? Fundamentally, it cannot do so. The videos and supporting scientific papers just presented offer no real adequate explanation as to how this invention works, devoid of violating the law of conservation of energy.



Then again, assuming PFGRT (inflowing space) is correct, for each and every time the pendulum swings back and forth (falls), it captures force from a new and continuously replenishing segment of the →accelerating factor of inflowing space (ether)←. Take note of, and this is crucial, in order for this over unity outcome to occur, the same object (like the pendulum) must "free fall" multiple times (oscillate), moreover, as a function of the inflowing ether accelerating factor.

This is not the case with regard to the kinetic drive experiment, for in that setting, it is a one-time "free fall" event.

To affirm this over unity assertion, let us now delve further into the concept. As a thought experiment, imagine, as illustrated and described above, the pendulum-powered water pump, however, in this case, →presume it is frictionless←. Therefore, as a function of the accelerating factor of inflowing space (ether) thereby producing the pendulum's "free falling motion," it then obtains acceleration/velocity.

However, since it is attached at its pivot, it begins to swing as a pendulum. As a result, it changes direction, which is another form of acceleration. Notice, as a function of only the pendulum's accelerating swinging motion, but not its accelerating "falling" motion, its direction changes, though the angular tangential velocity (ATV) does not.

In other words, there are two functions.

A. Function 1 is the free fall of the pendulum. Therefore, relative to this first aspect, the vertical translational velocity of the pendulum changes as a function of the linear accelerating factor of inflowing space/ether.

B. Function 2 is related to the pendulum's angular tangential velocity (ATV) due to the fact that it is attached at its pivot. So, regarding this second aspect, now as a function of only angular acceleration, its angular velocity does not change. Nevertheless, its direction goes from towards Earth to a way from Earth (angular acceleration).

To recap, translational acceleration (inflowing ether) produces a change in translational velocity. In contrast, angular acceleration (pendulum) does not alter ATV but instead, only its direction. In essence, translation motion and rotational motion are not the same physics.



**Figure 5.8** Pendulum Water Pump Assisted by Little Finger [Fair Use]

*“Continuous pumping of water with a little finger creates enormous efficiency concerning the input of energy up to 1,200 liters of water per hour without a major effort.”*

*So, as an explicit product of the pendulum’s swinging motion, as a function of its angular acceleration, it possesses angular velocity. In turn, from the location of the pendulum’s pivot, this angular acceleration generates a downward centrifugal force, as portrayed in Figure 5.8 above, specifically to the right of the fulcrum. This function, in turn, causes the water pump on the left side to oscillate up and down (work). Subsequently, that work is used for pumping water.*

Now before continuing, recall/review:

- A frictionless wheel set in vertical rotational motion generates persistent centrifugal/centripetal forces, as a function of continuous angular acceleration. In fact, presuming it is frictionless, theoretically, it will rotate forever. Essentially, there is no resistance to its ATV.

- The accelerating factor of inflowing space accelerates half of the wheel towards Earth and equally de-accelerates the other half a way from Earth, therefore, leaving the original induced angular acceleration/velocity intact/unchanged.

- (Function 1) The function of accelerating inflowing space does change the pendulum’s translational velocity, both as it moves towards and then, subsequently, away from Earth

- (Function 2) Alternatively, the function of the pendulum’s angular acceleration does not alter angular velocity, only its direction, so the centrifugal/centripetal forces remain constant.

These two functions are superimposed upon one another. However, in order to comprehend the following explanations, the reader must, in his mind, divide them into distinct separate concepts. Again, assume frictionless scenario.

1. At first, the pendulum free falls towards Earth from the acceleration factor of inflowing space. (F-1)

2. Then, because of the pivot, this motion is transformed into swinging angular acceleration/velocity from towards Earth to a way from Earth, moreover, without resistance, no change in ATV. (F-2)

3. Subsequently, the pendulum begins to climb a way from Earth, whereby a new segment of the accelerating factor of inflowing space slows, moreover, eventually stops that ascent. (F-1)

4. After that, another new portion of the inflowing ether initiates the same process all over again, then again, and a gain, and so on, and so forth. (F-1 then F-2 then F-1 and so on).

5. What is important to acknowledge is, at the bottom of each separate swinging motion, there is then a force directed towards Earth.

- If the apparatus is held rigid, then no work is achievable, even though the downward force remains.

- From another perspective, a gain presuming no downward work/movement as a function of force is permitted, the pendulum, after completing its first swing, returns to its original height above the Earth's surface, just as it was prior to the swing.

- What is more, as it swings back and forth, the same oscillating progression and outcome is repeated ad infinitum.

- Alternatively, as a function of the pendulum's angular acceleration/velocity, thereby producing a downward force, and assuming the apparatus is permitted to move in the same direction as the force, then work can be performed ( $W = F \times D$ ).

- Additionally, if downward work (movement) from force is executed (e.g., pendulum-powered water pump), then compared to the pendulum's original height above the Earth prior to the swing, its height above the Earth after the swing is reduced.

- Even so, the input work needed to maintain the pendulum swinging motion (height) is significantly less compared to the output work, according to Milkovic, by a Factor of 12.

Principally, in order for the pump to perform work, a portion of the pendulum's swinging motion is used or borrowed. Nevertheless, the overall amount of work borrowed from the swinging motion is significantly less than the work performed by the pump. So where does the over unity force/energy originate from? Energy is drawn from the continuous accelerating factor of the inflow of space/ether (gravitational field), to some extent, analogous to the production of energy as a function of water falling from a dam. Once this concept is acknowledged, other possibilities emerge as offered in the next sections.

Incidentally, if the reader is interested, the best websites for demonstrating this revolutionary invention are at:

*<http://bit.ly/2aPMWib> and <http://gravityassistedpower.com/photos/videos.htm>*

There are multiple videos available at these two websites. The author suggests the reader explore both sites. Each site listed above refers to the Gravitational Energy Corporation: *<http://bit.ly/2aPMWib>*.

The Gravitational Energy Corporation does not formally assert over unity; nevertheless, it does claim that by using a pendulum water pump, "then this allows the operator to work at the pump with at least five times less fatigue than any other hand-held operated pump. Therefore, the operator can pump 1,000 gallons per hour with very little effort."

Regardless of whether or not over unity is officially proclaimed by this company, after reviewing the videos, it is obvious over unity is present. The author has attempted to contact, furthermore, locate the Gravitational Energy Corporation to no avail. There is no longer contact information listed. Nevertheless, the company's website with its information is still accessible. So the owners must still want the information to be available for all of mankind.

For those individuals who want to learn even more about this subject, the following websites are also suggested. Over unity, which has already been shown in this section by Milkovic, also can be found at the first two websites. They clearly demonstrate over unity.

<https://www.youtube.com/watch?v=yCkVmv4zizM>  
<https://www.youtube.com/watch?v=8n7mvpLpP5A>

For both the physicists and nonscientists, these additional websites also demonstrate over unity.

<http://www.thescienceforum.com/pseudoscience/21344-pendulum-lever-system-overunity.html>

<http://www.greenoptimistic.com/serbian-overunity-device-free-energy-from-gravity-20090209/#.VSGOTNy4III>

<http://www.borderlands.de/Links/Two>

<http://www.veljkomilkovic.com/OscilacijeEng.html#measurements>

<https://www.youtube.com/watch?v=Y1cKWIAFT0I>

Regarding the last YouTube video listed above, notice that once the pendulum pump is set in motion by the operator, specifically at a given height, there appears to be over unity, because from that point on, no outside external work is added to maintain the continuously operating system. This is assuming the work performed by the air compression piston, which maintains the pendulum's motion, is a part of a closed system. However, with respect to this video, this effect is not entirely evident.

Now, please refer to figures 5.9 and 5.10 which demonstrate that a pendulum's swinging motion (like the playground swing) is a function of the conversion of GPE to KE and then back to GPE and so on and so forth.

---

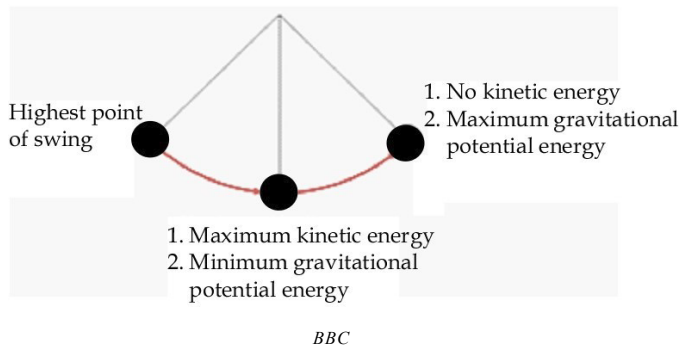

**Figure 5.9** Converting GPE to KE and Back [Fair Use]

*The pendulum/swing oscillates back and forth, GPE is converted to KE and then back to GPE and so on.*

---

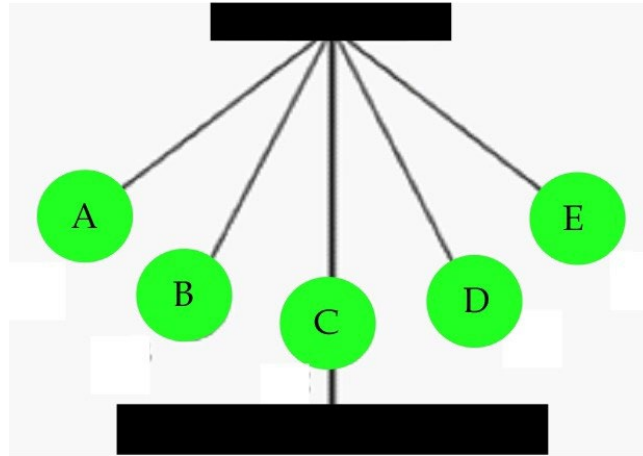

Kimberlytorresow19mp 06/25/2018

**Figure 5.10** Compression and Weightlessness [Fair Use]

*At positions A and E, you feel weightlessness, and at location C, you experience compression from force towards Earth.*

As another example, presuppose you are situated on a swing, oscillating back and forth. So, as you reach the apex of your upward motion and then begin to fall back down towards Earth, you feel weightlessness. In contrast, at the bottom of the swing, whereby you reorient from towards Earth to a way from Earth, you then experience compression.

And so, for each and every time you oscillate back and forth, at the bottom of that motion, a force is exerted on you, as well as the swing, moreover, oriented towards Earth. In addition, presuming a frictionless system, this recurring force occurs ad infinitum. Furthermore, with respect to this closed system, other than the KE/GPE combination, there is no other energy accessible.

Again, bear in mind, the ether does not resist an object's velocity, whether it is translational velocity or the angular velocity of a rotating wheel. As an example, again regarding the latter, a spinning wheel, including a vertical spinning wheel devoid of friction will theoretically rotate forever, furthermore, producing an endless centripetal/centrifugal force. Fundamentally, as you swing back and forth, there is no resistance to your angular velocity from the ether.

The swing:

- (Function 1, translation motion) Assume, vis-a-vis this new theory, inflowing space accelerates both you and the swing towards Earth.
- (Function 2, angular motion) But, because of the swing's pivot, your accelerated direction is altered, which transforms your downward motion into angular velocity/acceleration. In addition, as you change direction from towards to away from Earth, there is no change in your tangential angular velocity.
- Even so, at the bottom of the swing, you still feel compression (force) towards Earth.
- (Function 1, translational motion) Then, eventually, as you begin to climb away from Earth, a new portion of the accelerating factor of the inflowing ether slows and ultimately reverses your ascent, whereby the process then repeats itself.

- Again, presupposing a frictionless system with no work permitted, this oscillating function, including the production of downward force continues endlessly.
- Alternatively, at the bottom of the swinging motion, at the position where there is a downward force, if you and the swing are allowed to move towards Earth (e.g., pendulum-powered water pump), work is performed (force X distance).
- If this occurs, then as you again swing away from Earth, your height, after the swing, is now less than before the swing.
- What is more, in order to maintain the swing's original height, the amount of input work required is considerably less compared to the output work performed at the bottom of the swing.
- This outcome cannot be explained by classic physics; it is an over unity hypothetical model.
- In contrast, if force and energy are extracted from a continuous inflow of the accelerating factor of the inflowing ether, then this is the source of the over unity.
- This hypothesis also gives explanation to the previous listed YouTube videos and explanations regarding Milkovic's inventions.

**The author has one more reflection.** Numerous other experimenters have proclaimed over unity inventions. Even so, given that they all contradict the law of conservation of energy, they are ridiculed, ignored, and perhaps, even suppressed. However, if Milkovic's pendulum-powered water pump invention proves genuine, which the author believes is true, then the classic law of conservation of energy is in erratum. Presuming this is so, then this opens a pathway for acceptance by the scientific community, even perhaps, for all of mankind of the potential for other over unity inventions. Hopefully, closed minds will then be open to new concepts, ideas, and developments, including other over unity devices.

### 5.2.3 The Rotating Wheel with Attached Buckets and Pistons.

Now, assuming that the over unity pendulum-powered water pump works as advertised, then so should this hypothetical device, since both concepts are based upon the same inflowing ether hypothesis (PFGRT).

The next series of figures, followed by written dissertations, is the methodology by which the author has chosen to explain this concept. So, to begin with, please refer to figures 5.11 and 5.12 below.

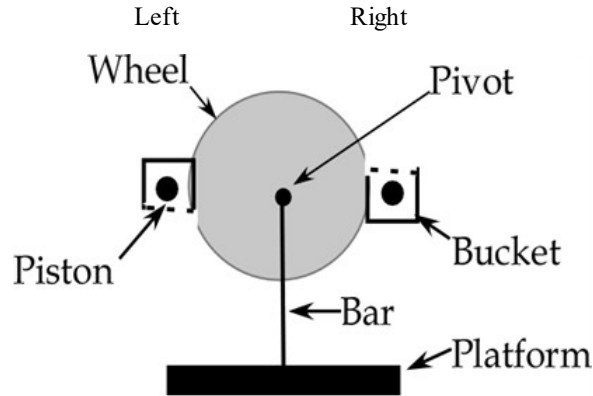

**Figure 5.11** Rotating Device with Attached Pistons in Buckets

*Figure 5.11 depicts the overall physical structure of the device.*

(See Figure 5.11 above.) Picture in your mind a wheel capable of rotation. Additionally, envision, as depicted above, that the wheel is attached at its pivot to a vertical bar and then the bar to a platform, the latter located on the Earth's surface. Then, imagine that on opposite sides of the wheel there are fixed buckets, each of which contains an attached piston, which can freely move in and out. Observe, in Figure 5.11, both pistons are located inside of their respective buckets.

Refer to Figure 5.12 below (Time 1). →Assume the wheel is stationary←. At Time 1, the initial orientation, presume the left piston is located within its bucket, whereas the right piston is extended outside, as shown below.

Later at Time 2 (Figure 5.13), given that the opening of the left bucket faces towards Earth, its piston "falls" out. Moreover, since it is attached, it produces a torque towards Earth.

On the opposite side, the right bucket's opening faces away from Earth; furthermore, its piston is extended outside. Consequently, it falls into its bucket, again generating a torque towards Earth. Now, if one presupposes that the wheel is stationary, these torques are equal as well as symmetrical. Therefore, as a function of this coupled function, there is no initiation of rotation.

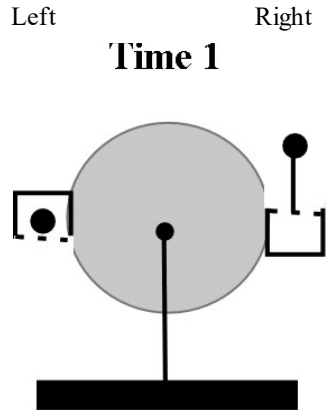

**Figure 5.12** Starting Position

Figure 5.12 shows the orientation of the device at the starting position defined as Time 1. In addition, assume the wheel is stationary.

At Time 1, the initial orientation, presume the left piston is located within its bucket, whereas the right piston is extended outside, as shown above.

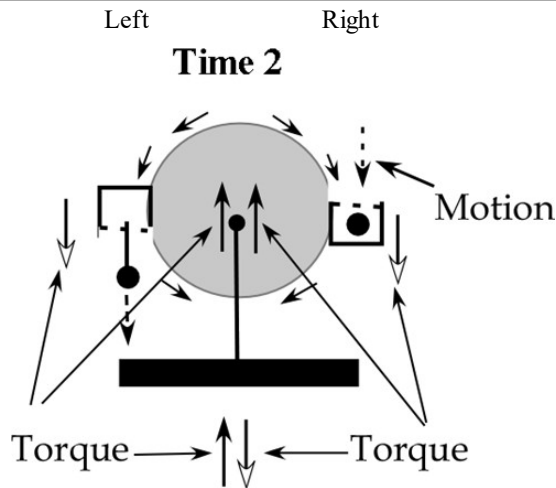
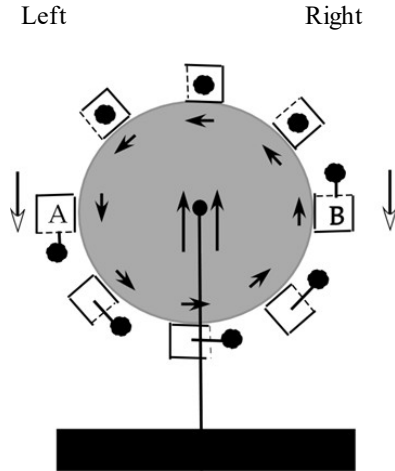

**Figure 5.13** Pistons Falling into and out of the Bucket

Again, presuppose no initial rotation. Time 2 is when the two pistons "fall" towards Earth. Now, as the left piston falls out of and the right piston falls into its bucket, then equal, symmetrical, and bilateral torques are generated. And so, for that reason, there is no initiation of rotation. As shown, a torque is a coupled function of two forces. The right half of the wheel is trying to rotate clockwise and the left half counterclockwise. As a result, they counteract one another and the wheel remains stationary.



On the other hand, what transpires when the wheel is initially rotating? See Figure 5.14 below.



**Figure 5.14** Position of the Pistons Relative to their Respective Buckets during 360 Degrees of Rotation.

*A is the left bucket/piston. B is the right bucket/piston. When the wheel rotates counterclockwise, B exchanges places with A and vice versa. This schematic demonstrates the changing orientations of the pistons relative to their respective buckets during 360 degrees of rotation.*

Figure 5.14 as shown above is a schematic of the relative positions of the pistons/buckets as a function of the wheel's 360 degrees of rotation.

Now, refer to figures 5.15 and 5.16 below. These two figures demonstrate what transpires when the wheel is rotated, first rapidly (Figure 5.15) and then at a slower rate (Figure 5.16). Each figure is followed by a discussion.

Assume the wheel (Figure 5.15 below) is rapidly rotating counterclockwise as portrayed. Due to the centrifugal force, the pistons remain within their respective buckets, presupposing they were there to begin with.

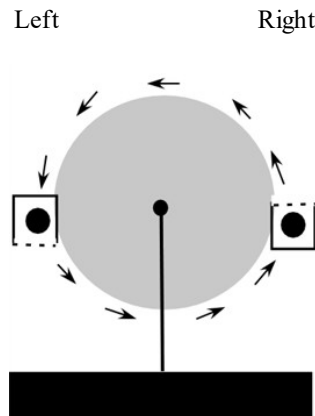

**Figure 5.15** Rapid Rotation

*During rapid rotation, moreover assuming the pistons are initially located inside their respective buckets, the centrifugal force then maintains those positions. As a consequence, they remain within their respective buckets.*

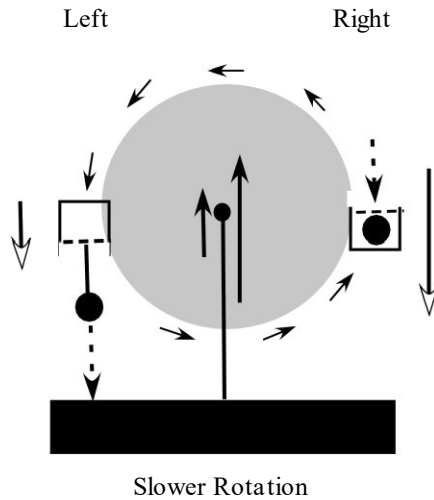

**Figure 5.16** Fall of the Piston with Slower Rotation

- *The dotted arrows depict the direction of the "fall" of the piston.*
- *The solid arrows, arranged in a circle around the wheel, denote the direction of rotation, counter-clockwise.*
- *The vertical solid/hollow arrowheads depict the torques. A torque is a coupled function of force. One force is derived from the "falling piston" towards Earth (hollow arrowhead), while the other force is located at the pivot, moreover, oriented in the opposite direction (solid arrowhead).*

See Figure 5.16 above. As the wheel's rotational rate slows from friction, then relative to their associated buckets, the pistons cyclically and sequentially begin to move in and out as already presented in Figure 5.14.

For that reason, as shown in Figure 5.16, the torque generated on the left side is significantly less compared to the torque on the right (see discussion below). So at this point in time, the wheel suddenly slows down rapidly. More importantly, this sudden reduction is not related to friction nor, for that matter, from classic gravitational potential energy (see discussion below).

Please pay close attention now, for here is the key concept. When the piston on the left side falls out of its bucket, it exerts less torque as compared to the right side, whereby it falls into its bucket. This is because on the left side, the piston falls in the direction of rotation, whereas on the right side it falls against the direction of rotation. → Unlike the previous stationary example, moreover, as a result of the unequal torques, with respect to this scenario, there is an abrupt and rapid reduction in the wheel's rotational rate. But most importantly, this effect is not related to friction ←.

Here is the key question: From where does the force originate causing the wheel to rapidly slow down? It cannot be from gravitational potential energy, since for every 360 degrees of rotation, the buckets and pistons return to their original orientations (height above Earth).

Strictly speaking, while rotating, whatever gravitational potential energy is used up on one side is then returned on the other side. For that reason, one cannot give explanation to the results of this experimental device utilizing the classic concept of gravitational potential energy.

In contrast, as with the pendulum drive/kinetic drive experiments, it can be understood by using the inflowing ether theory (PFGRT). Again, this new theory assumes there is a continuous inflow of accelerated space (force), which is then utilized to slow the wheel's rotational rate.

This system only works if the pistons repetitively "fall" to Earth as a function of the accelerating factor of inflowing space, just as with the pendulum water pump.

In essence, again, the energy and force that rapidly slows the wheel's rotation is derived from the "repetitive fall" (rotating oscillation) of the pistons. In turn, this is a function of the inflow of accelerating space (ether). This concept is analogous to a waterfall, whereby force and energy are produced from a continuous stream of falling water. But with reference to PFGRT, it is from the continuous accelerating factor of the inflowing ether.

As usual, in science, it is not that simple. For example, the torque directed towards Earth on the right side is greater than on the left side, but the time of flight of the piston on the left is longer than on the right, since it is "falling" in the direction of rotation. Therefore, at various times, there are unequal inertial masses relative to the two halves of the wheel.

Nevertheless, overall, this author knows this device works because a somewhat similar working model has actually been built and functions as advertised. It is pictured below and in the following schematic. See figures 5.17 and 5.18 below.

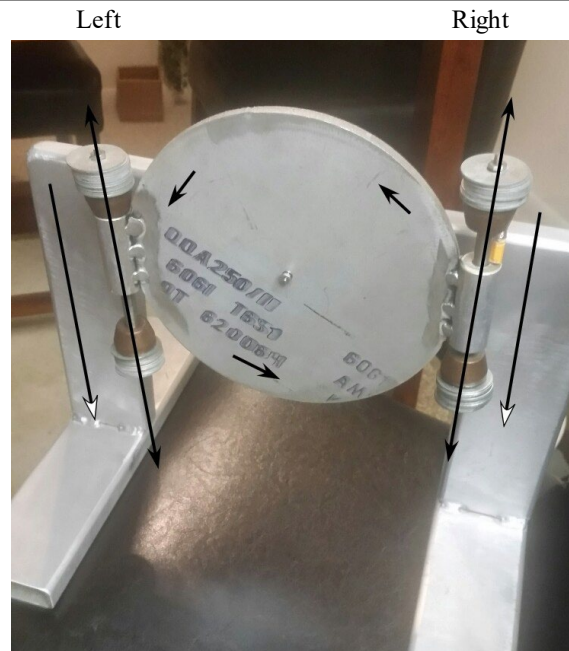

**Figure 5.17** Actual Experimental Rotating Wheel

*The arrows located on the face of the wheel depict the direction of rotation, counterclockwise. The double-headed black arrows show, during rotation, how the pistons slide up and down relative to the holders. The hollow-headed arrows depict the direction of the fall of the pistons.*

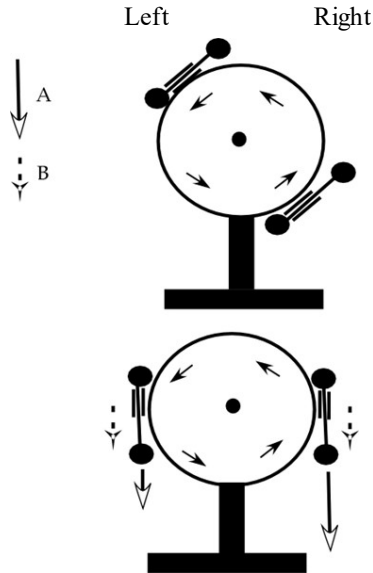

**Figure 5.18** Rapid Slowdown

- $A = \text{force}$  and  $B = \text{motion}$ .
- The small dotted arrows symbolize the direction of the fall of the barbell-like pistons. The larger hollow-headed solid arrows depict the amount of force/torque directed towards Earth ( $R > L$ ).

See figures 5.17 and 5.18 above.

As the wheel continuously rotates counter-clockwise, both barbell-like pistons fall to Earth. On the left, since the fall is in the direction of rotation, there is then less force (torque) directed towards Earth, versus the right side whereby the fall is against the direction of wheel's rotation. Therefore, the wheel rapidly slows down, moreover, without using GPE.

Now, consider this logic. →assuming no friction← or air resistance, if one captures some of the force that slows the wheel's rotation rate, (as a result, the torque is then equal on both sides), moreover, uses it for the production of energy, the wheel will not slow, even in the presence of constant energy extraction. Obviously, this has practical implications, for if real, there is an endless supply of pollution-free energy, located anywhere on Earth or, for that matter, on any planet with gravity.

As an example, imagine a massive wheel associated with numerous surrounding buckets/pistons.

Additionally, if one envisions that the pistons, while in the process of "falling" into their respective buckets, on the right side, compressed the atmosphere, but in contrast not while "falling out" on the left side, then the compressed air could be used to drive a turbine. Furthermore, relative to the right side, this function would diminish the pistons' "rate of fall" into their respective buckets. In turn, the torque on that side would then be reduced.

What's more, if sufficient energy was extracted, then the torques generated relevant to both sides could be equal. Assuming all of this actually occurs, the wheel's rotational rate would remain unchanged, even with constant energy extraction (assume a frictionless system). Moreover, if additional energy was extracted, then the effects of friction could be overcome or else the wheel rotational rate could even increase.

This hypothetical device sounds fairly simple although it is not, for there are many intricate factors involved, including gyroscope torque effects related to spinning turbines located on a large rotating wheel. As a result, this device, when compared to a pendulum-powered water pump is much more complicated, therefore, considerably less practical.

The author now refers the reader to the four websites given below:

1. <https://www.youtube.com/watch?v=rbCnzsFjvQU>
2. <https://www.youtube.com/watch?v=88Z2x1MEex8>
3. <https://www.youtube.com/watch?v=rsBplmMDcRQ>
4. <https://www.youtube.com/watch?v=DsvPICaiVjI>

After reviewing these four websites, hopefully, the reader will begin to understand where the force originates from that keeps the unbalanced wheel continually rotating. The inflowing, accelerating space theory explains the underlying physical principles of this form of overunity.

#### 5.2.4 The Ferris Wheel

See, Figure 5.19 of a Ferris wheel and the following discussion.

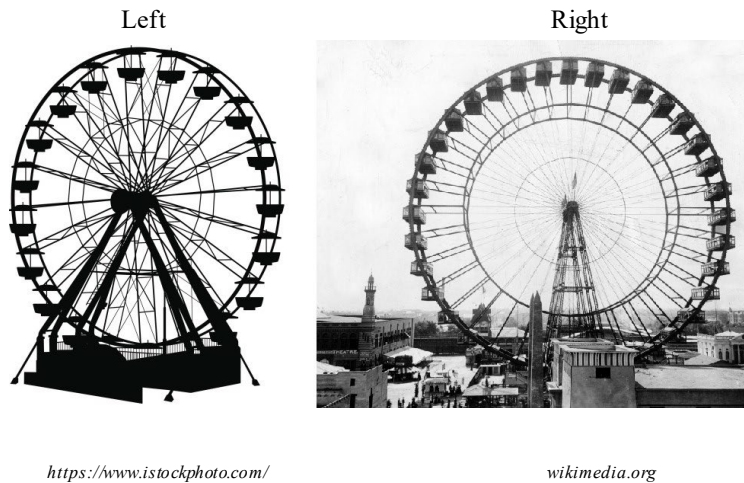

**Figure 5.19** Ferris Wheel Rotating Counter Clockwise [Fair Use]

The author observed that when he carried a small ball with its attached rubber string onto a Ferris wheel (FW), and let it hang down during the FW's rotation, it behaved as revealed below. When moving in the direction away from Earth (right), the string stretched significantly more compared to when traveling towards Earth (left). In addition, the author felt compression (force) while moving from Earth and relative weightlessness traveling to Earth.

→Assuming a frictionless system←, moreover, presupposing no air resistance, therefore, no need for a motor drive, hypothetically then, once rotation is initiated, the FW, the author, and the ball on the string would revolve ad infinitum, devoid of energy input. Consequently, as a function of 360 degrees of rotation, the ball with its string would cyclically and repetitively stretch and then contract theoretically forever, again without energy input. This oscillating movement is the definition of work ( $W = F \times D$ ).

Additionally, this work (energy) could then be extracted, such as for the production of electricity, without decreasing or only minimally reducing the Ferris wheel's rotational rate. So

supposedly, just as with the pendulum water pump, the amount of work to maintain the FW rotational rate should be significantly less than the output work used to produce the electricity. The inflowing accelerating factor of the ether acting upon a repetitive oscillating falling object is the origin of the over unity energy. Again, this concept is contrary to the law of conservation of energy but is consistent with PFGRTE or using the new lexicology, the **inflowing ether**.

→ As an aside, take note. With respect to a classic/typical/balanced FW located at a carnival (this time without the buckets/pistons, furthermore, assume no friction and no motor drive), the gravitational force directed towards Earth is equal on both sides of the FW, which maintains its rotation, but the compression is only evident while moving away from Earth. Even so, this compression effect does not reduce the FW's rotational rate. For future reference, regarding inertial mass addressed later in this chapter, remember this concept←.

As an adjunct, moreover, to further give explanation to this concept, the following device, though imaginary, is presented which could have practical value, although in no way matching the proven pendulum water pump. It is offered for an entirely different purpose as spelled out in the summary. Refer to Figure 5.20.

As already hypothesized, presume a rotating frictionless →balanced← FW structure oriented as just depicted. However, in this scenario, substitute the rubber ball with a permanent bar magnet (PM), still attached to the rubber string. In addition, presuppose its down and then up oscillating motion (on the right side of the FW) takes place adjacent to a straight copper wire conductor, which itself is fixed to the FW. For that reason, during the FW's rotation, moreover, specifically in the direction away from earth (right), the PM will oscillate first down, then up, relative to the adjacent fixed copper wire conductor.

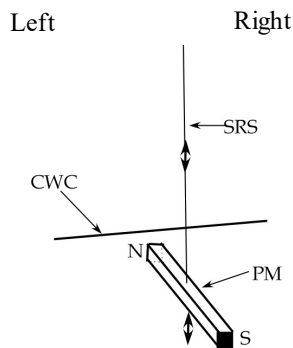

**Figure 5.20** Inducing Current in Copper Wire

- *SRS = Stretchable Rubber String*
- *CWC = Copper Wire Conductor*
- *PM = Permanent Magnet*
- *Double Black Arrows = Up and down motion relative to the CWC*
- *As the permanent magnet moves up and down relative to the fixed conductor, a current is generated.*

Therefore, as a result of this relative motion, a current would be induced; furthermore, it could be extracted.

The induction of the current does not significantly slow the FW's rotation (thus over unity). This is because, regarding the production of the current, moreover, as a function of 360 degrees of rotation, the sum total of all the forces, including the Lorentz forces exerted on the PM, conductor, and FW, counteract one another. Principally, these are balanced forces.

As another aside, if a practical device is ever built, hundreds of these devices could be associated with a single mega-giant Ferris wheel.

The author is not entirely convinced of the validity of this concept, for it is extremely multifaceted, in fact, too complex to resolve without intricate math. Even so, it is a great mental exercise.

Regarding PFGRT, the only over unity energy available is from the PM repetitive, free-falling motion during multiple rotations, **moreover, as a function of only the accelerating factor of inflowing space/ether**. This oscillating motion is what produces multiple stretches and then contractions of the rubber string and its attached PM. Remember also, the stretched rubber string is a form of potential energy.

Now, as just described, presuppose there are multiple separate interacting bar magnets, rubber strings, and conductor wires, however, at this time, evenly distributed over 360 degrees (FW). In addition, vis-à-vis the following discussion, the positive numbers indicate an increased rotational rate, whereas the negative numbers represent a decreased rotational rate of the FW. Assume the FW rotates counterclockwise and presume no friction.

- [+1] So on the left side, while the PM is in the process of →rotating← towards Earth, but on the right →falling← to Earth, then for that interval of time, the inertial mass of the left half of the FW is greater compared to the right side. Therefore, as a result of this asymmetry, the FW's rotational rate increases.

- [-1] In addition, on the right, when the PM falls, moreover, as it interacts with the wire conductor to create a current, the action then reduces its "rate of fall." Simultaneously, a force is exerted on the wire conductor, which then slows the FW's rotation.

- [-2] Furthermore, as the rubber string stretches, this function creates a force that also slows the wheel's rotational rate.

- [-3] Later on, when the PM returns, as a function of stored potential energy within the rubber string, the interaction with the conductor then decelerates the PM's "rate of return" by force, again slowing the FW's rotation.

- [+2] However, at the same time, this function also places a force on the conductor wire, which increases the FW's rotational rate.

- [+3] What is more, the string's "de-stretching" function also increases the rate of rotation.

Now, given all of the above, relative to the induction of the current, the sum total all the forces are balanced; accordingly, there is no decrease of the FW's rotational rate.

Obviously, for the reader, but especially for the nonscientist, this explanation is extremely complicated, moreover, probably very confusing. For that reason, the author will now re-explain it from a different perspective. Referring to the left half of the FW, as it rotates/travels towards Earth, the PM hangs relatively motionless on its string. So in this setting, it does not interact with the conductor wire. The inertial mass of the left half of the FW remains relatively constant.

In contrast, with regard to the right half of FW, the PM, while rotating from the bottom to the apex, along with the FW, oscillates first down, then up. Therefore, relative to the copper wire conductor, this motion induces a current in both directions.

So, with regard to the right side, whatever overall forces are exerted on the FW during the PM downstroke, they are counteracted by anti-symmetrical forces exerted on it by the upstroke.

Since work is used to induce the current, there may be a slight reduction of the FW's rotational rate, but only related to the sum total of the Lorentz forces, exclusively on the right side of the FW. However, as previously denoted, this reduction in rotation is counteracted by augmented rotation, as a function of the relative increased inertial mass on the left compared to

the right, which occurs during the time of the "fall" of the PM on the right. So, again overall, a current is produced without a significant reduction in the Ferris wheel's rotational rate.

Nevertheless, in reality, again, there may indeed be a small overall reduction of the FW rotational rate as a function of current production. But the input work, in order to maintain the rotational rate of the FW, would be significantly less compared to the output work used for the production of the current—analogous to the pendulum powered water pump.

### Summary

This model is so intricate that it obviously requires mathematical proof too complex for this author. Nevertheless, as with the pendulum water pump, the underlying rationale for why the author chose to present this Ferris wheel example is to reinforce the idea that the over unity energy generated/captured is always related to the repetitive fall of an oscillating object, moreover, as a function of accelerating factor of inflowing space (ether).

## 5.3 The Homopolar Motor and Homopolar Generator

### 5.3.1 The Homopolar Generator

### 5.3.2 The Homopolar Motor

*A physical law or scientific law is a theoretical statement inferred from particular facts, applicable to a defined group or class of phenomena, and expressible by the statement that a particular phenomenon **always** occurs if certain conditions be present. Physical laws are typically conclusions based on repeated scientific experiments and observations over many years and which have become accepted universally within the scientific community. <http://bit.ly/2a1Dta19>*

If a law of physics is truly a law, then there should be absolutely no exceptions. However, assuming there is, then by some definitions, it is not a law. The homopolar motor/generator combination appears to defy Newton's third law, as well as Einstein's relativity principle. This conundrum will now be clarified. To do so, first, the homopolar generator will be discussed, then the homopolar motor, both as functions of **the ether**.

For the nonscientist, before reading this section, viewing the website given below would be helpful. This site titled, "Electromagnetism - Maxwell's Laws," explains the classic interpretation of electromagnetism.

*<https://www.chegg.com/homework-help/definitions/maxwells-laws-of-electromagnetism-2>*



### 5.3.1 Homopolar Generator

A schematic of the homopolar generator is shown in Figure 5.21 below. This is followed by a written description of its structure, then its function, and finally, how it relates to the existence of **the ether**.

---

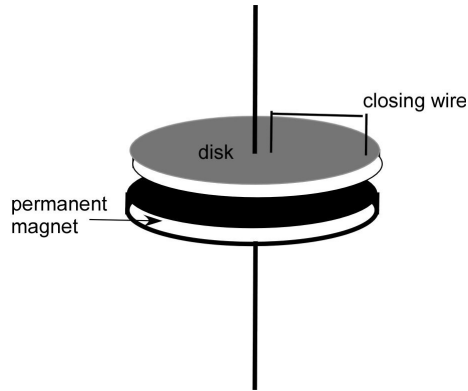

**Figure 5.21** Schematic of the Homopolar Generator

---

#### Structure of the Homopolar Generator

- A. The upper disk is a copper conductor (defined as disk). In addition, it is attached to a vertical pole.
- B. The copper disk is capable of independent rotation relative to the pole and vice versa.
- C. The magnet is a permanent circular disk magnet (defined as magnet). Its north-south axis is aligned parallel to the vertical pole. It is also attached to the vertical pole.
- D. The magnet is separated by a space apart from the disk. In addition, the magnet can independently rotate with regard to the disk and vice versa.
- E. The closing wire is a copper wire conductor, which connects the center of the disk to its periphery.

#### Function of the Homopolar Generator

- A. If the disk is rotated by force relative to the stationary magnet, then a current is generated.
  - B. If the magnet is rotated by force but the disk remains stationary, then no current is produced.
  - C. If the disk is rotated synchronously along with the magnet, a current is again induced.
- This type of generator obviously violates Einstein's relative motion principle. This is because rotating the disk relative to the magnet (A) does not have the same effect as rotating the magnet relative to the disk (B). In addition, simultaneously rotating the magnet along with disk still produces a current (C). Again, with respect to (A) and (B), this violates Einstein's relativity principle. Furthermore, regarding (C), even though a current is induced, there is no relative motion of the disk versus the magnet. So, there must be a synchronous movement of both relative to something else. And what is that? **The ether**.

### 5.3.2 Homopolar Motor

The homopolar motor is structured as presented in figures 5.22, 5.23, and 5.24 below. This is followed by a written description of its structure, then its function, and finally, how the function relates to the existence of the ether.

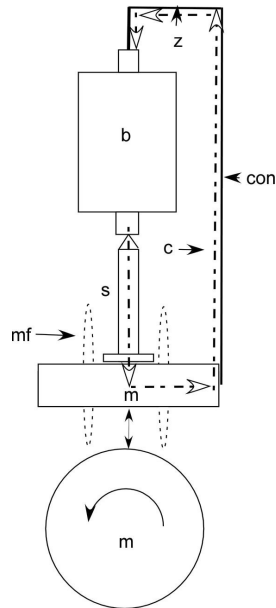
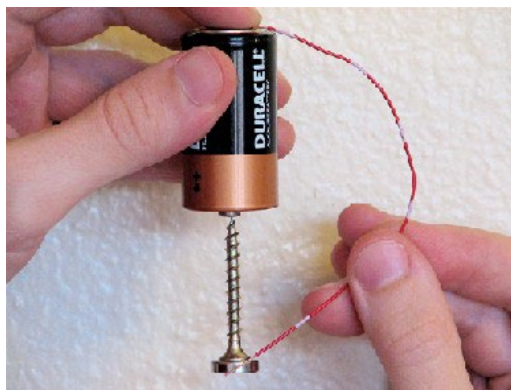

Figure 5.22 Drawing of Motor with Battery and Nail



Wikimedia Commons

Figure 5.23 Picture of Actual Homopolar Motor [Fair Use]

In these figures, 5.22 and 5.23, the conductor and magnet are one in the same, since the permanent magnet possesses a nickel coating, which functions as the conductor. See Figure 5.22 above for labeling as shown below.

- B = battery

- $m$  = nickel coated permanent magnet
- $mf$  = magnetic field
- $con$  = closing conductor wire
- $c$  = current (dotted line)
- $s$  = steel nail
- arrow on  $m$  = direction of rotation

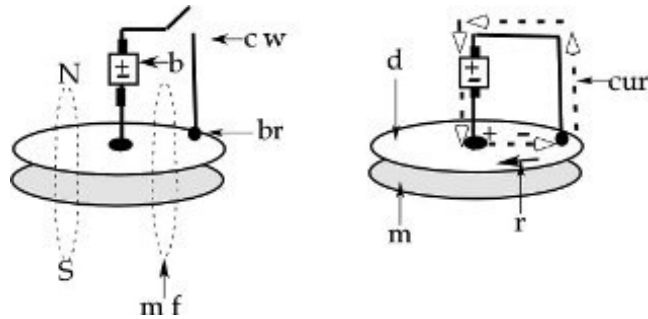

**Figure 5.24** Disk and Magnet are Separate Structures

*In this second example, the disk conductor and disk magnet are two separate structures.*

- $d$  = disk conductor/magnet
- $cur$  = direction of current
- $m$  = magnet
- $+$  = positive charge
- $mf$  = magnetic field
- $-$  = negative charge
- $cw$  = closing wire
- $B$  = battery
- $br$  = brush
- $r$  = rotation direction

#### **Structure of the Homopolar Motor (See only figures 5.22 and 5.23.)**

A. The disk-shaped conductor magnet combination is attached to the flat base of the metal screw as shown. Therefore, it magnetizes the screw.

B. The tip of the magnetized screw with its attached magnet is then placed in contact with the battery's lower electrode, moreover, becomes attached, since it is now magnetized.

C. One end of the closing wire is attached to the battery's upper electrode, whereas the other end, by the use of a brush, gently touches the outer side of the magnet/conductor disk. Even so, the brush still allows the magnet/conductor disk to freely rotate.

### Function of the Homopolar Motor

Before proceeding, recall the production of the Lorentz force is as shown in Figure 5.25 below. Furthermore, recollect that when the current and the magnetic field lines are parallel, there is no Lorentz force.

---

#### Fleming's Left-hand Rule

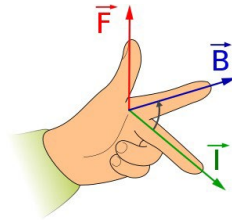

Wikimedia Commons

$B =$  magnetic field;  $I =$  current;  $F =$  force

**Figure 5.25** Lorentz Force using Left-Hand Rule [Fair Use]

*Orientation of Lorentz force with respect to the direction of the current, as well as of the magnetic field.  
Left-hand rule for an  $\rightarrow$ electron-carrying current $\leftarrow$  in a magnetic field  $B$ .*

---

See Figure 5.26 below. The function of the homopolar motor is now divided into segments a, b, c, d, e, f.

*Segment a.* The current passes vertically down from the battery's lower electrode through the metal screw. Now, concerning only this segment, the current and magnetic field lines are parallel to one another. Therefore, no Lorentz force is generated.

*Segment b.* The current then turns horizontal as it traverses through the magnet/conductor disk. Regarding this specific segment, given that the current and magnetic field lines are perpendicular relative to one another, a Lorentz force is then generated. Therefore, the disk rotates.

*Segments c, d, e, f.* The current subsequently enters the copper closing wire segment, whereby it returns to the battery's upper electrode. Referring to these segments, there are Lorentz forces generated. However, these forces will be deliberated later on in this section.

Again, concerning only the conductor/magnet segment labeled b, a Lorentz force is generated. This is because at this location, the horizontal current interacts with the vertical-oriented magnetic field lines. This function then induces a sideways Lorentz force, causing the magnet/conductor and screw to rotate. A brief video of this motor can be found at <http://bit.ly/2aPQ07e>.

Here is the crucial concept. From the reference frame of only segment b (the disk conductor/magnet combination), there is no equal and opposite reaction force. Otherwise, there would be no rotation. Nevertheless, there could be an equal and opposite force exerted on the closing wire, divided into segments c, d, e, and f as shown below in Figure 5.26.

Observe the portion of the closing wire section specifically labeled c (Figure 5.26), which extends outward parallel to the conductor/magnet's plane. At this location, as revealed below, the magnetic field lines reverse orientation. For that reason, the Lorentz force exerted on this specific portion of the closing wire (c) is then oriented in the opposite direction when compared to the conductor magnet segment b.

On the other hand, if the closing wire followed the field lines for a given distance, parallel rather than perpendicular, as shown in Figure 5.27 below (moreover, subsequently completed the circuit), then the two scenarios for opposing Lorentz forces *possibly* would not be the same.

Basically, there are different opposite Lorentz forces exerted on the closing wire (segment c) depending upon whether it initially follows the field lines or doesn't.

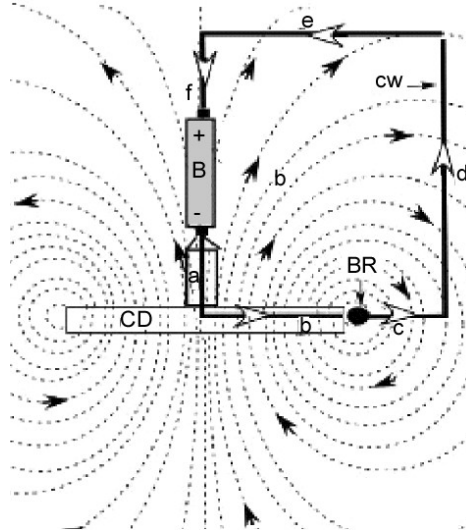

**Figure 5.26** Segments Show the Function of the Homopolar Motor

- *a* = metal screw
- *B* = battery
- *CD* = conductor or disk
- *BR* = brush
- *b* = segment B magnetic field and current perpendicular to one another = conductor magnet segment
- *CW* = closing wire
- *c* = segment C, first segment of closing wire
- *d, e, and f* = second, third, and fourth portion of closing wire

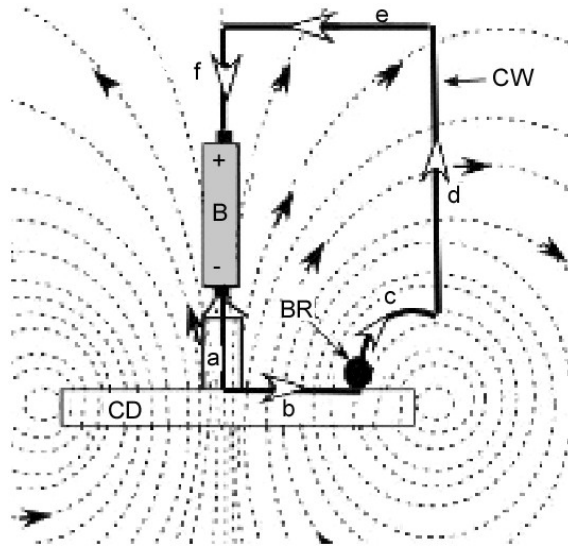

Figure 5.27 Segment c Follows the Field Lines

Nevertheless, concerning this specific example, this concept may not be germane, because, as shown above, (compare Figure 5.27 to Figure 5.26) there is a reduction of the Lorentz forces located in both segment b—since b is shorter—as well as the curving closing wire segment, labeled c, as it now follows parallel to the field lines, so in this specific example, no Lorentz force (c).

Alternatively, the amount of distance by which the closing wire segment c follows the field lines could be varied, moreover, without affecting segment b (Figure 5.27). Therefore, given this circumstance, a violation of Newton's third law would apply.

Principally, (Figure 5.27), the conductor/magnet segment b is associated with only one Lorentz force, which produces rotation. In contrast, referring to the Lorentz force of segment c, there are two or more possibilities. So, by logic, the opposing forces cannot, in all instances, be equal and opposite.

The Lorentz forces associated with closing wire segments d and e are minimal, given that they are located at a distance from the magnetic field. What is more, segment f is parallel to the field lines, so there is no force.

Additionally, there is a force located at the junction of the nail with the lower battery's electrode. But this force is oriented in the same direction when compared to the Lorentz force produced by the conductor/magnet segment b.

In summary, given all of the above, it is obvious that the sum total of all the Lorentz forces located within a closed system of this nature are not, in all instances, equal and opposite. Consequently, this device violates Newton's third law.

The above description, especially for the average individual without a scientific background, is probably very confusing. So, to simplify the explanation, here is the fundamental concept of this mental exercise. How does the conductor/magnet segment (b) produce rotation devoid of an equal and opposite reaction force? By Newton's third law, it cannot do so; nevertheless, it does. So, what does the conductor/magnet segment b push against? The answer is **the ether**.

## 5.4 Electromagnetic Propulsion without a Propellant

Given the fact that Newton's third law forbids it, it is assumed that an object positioned in the far reaches of outer space cannot self-propel linearly without the use of propellant. The purpose of the following four examples, some of which are actual experiments, is to demonstrate that this presumption is false.

The list is given below.

- 5.4.1 Propulsion from the Rectangle
- 5.4.2 Propulsion of the Railgun; a Hypothetical Presentation of the Theory
- 5.4.3 Propulsion of the Railgun; a Practical Device
- 5.4.4 Propulsion of the Ring

### 5.4.1 Propulsion from the Rectangle

#### Structure

Before reading this section, the following website would be helpful for the nonscientist.  
<http://bit.ly/2aCjS5A>

The →hypothetical← experimental device offered below consists of 14 2" x 2" square 1/8-inch-thick neodymium permanent magnets assembled in the form of a rectangle, as revealed in figures 5.28 and 5.29.

First, a photo (Figure 5.28), second a three-dimensional drawing (Figure 5.29), and finally three-view drawings (figures 5.30 through 5.32) are presented. Subsequent to this, there is a detailed written explanation of its structure, moreover, its function.

The parallel dotted lines located on the top and bottom of the rectangle in Figure 5.30 below symbolize thin metal strips sited at the junction between the adjacent attached square magnets. Then see photos (figures 5.28 and 5.33 and captions). Furthermore, as pictured, L brackets are positioned at the corners for stabilization Figure 5.28.



**Figure 5.28**

*Photograph of multiple square neodymium permanent magnets assembled in the form of a rectangle with metal braces for stabilization placed at the angles/corners.*

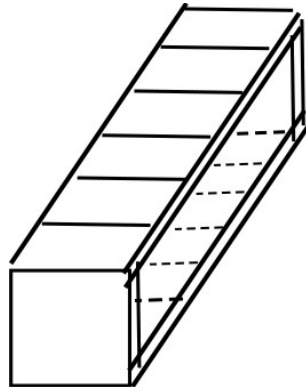
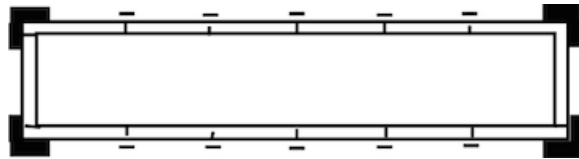

**Figure 5.29** Square Magnets, Top, Bottom, and Ends

*There are six attached square neodymium magnets on the top, six magnets on the bottom, and one on each end; the two long sides are open.*



**Figure 5.30** Top View



**Figure 5.31** Side View

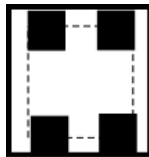
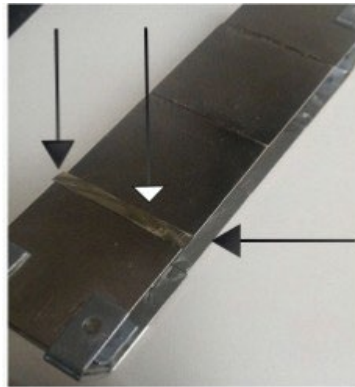

**Figure 5.32** End View

*The black squares depict L brackets placed at the corners and used for stabilization of the rectangle.*

---





**Figure 5.33** Metal Strips for Rectangular Propulsion (see arrows)

*Thin metal strips are sited at the junctions of adjacent square magnets. Only one is shown above. This metal strip blocks a reversal of the magnetic field lines at that location.*

Here is the written description (see figures 5.29 through 5.32 above). The assembly’s two lengths and ends are fashioned from attached square neodymium magnets, six on the top, six on the bottom, and one on each end, for a total of 14. The width of the assembly is left open (side view Figure 5.31).

The south magnetic field lines are all oriented towards the outside of the rectangle. Again, at the junction of the attached square magnets there is a small metal strip, which covers that joint (see Figure 5.33 photo). This strip blocks a reversal of the field to north in that region. Furthermore, at the corners, there are L brackets as well as plates used for stabilization.

See Figure 5.34 below. The rectangle assembly is then covered with heat-resistant electrical tape. Subsequently, peripheral to this, a two-inch-wide copper sheet is consigned surrounding the rectangle with its two ends attached to a capacitor, the latter of which is located at the top midpoint of the rectangle. After that, the copper sheet is covered with an additional second layer of heat-resistant electrical tape.

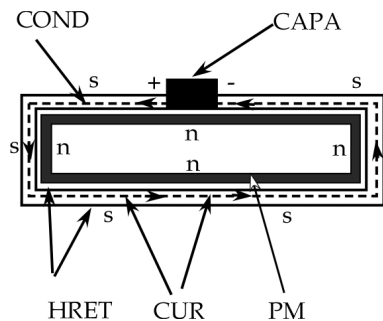
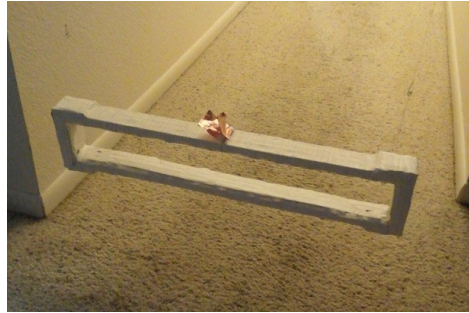

**Figure 5.34** Side View of Rectangular Assembly

- *CUR = current in copper sheet.*
- *S and N = direction of magnetic field.*
- *COND = copper sheet conductor, dotted line.*
- *CAPA = capacitor, square box on top.*

- *HRET* = heat-resistant electrical tape, thin black lines.
- *PM* = permanent magnets, thick black line.
- *BLACK ARROWS* = direction of current.

See Figure 5.35 below. The rectangle is then suspended, analogous to a pendulum by using fishing lines as pictured below.



**Figure 5.35** Rectangle Suspended with Fishing Lines  
*Note the image presented contains a different number of attached neodymium magnets, but the principle is the same.*

**Function**

Recall the Lorentz force shown previously in Figure 5.35.

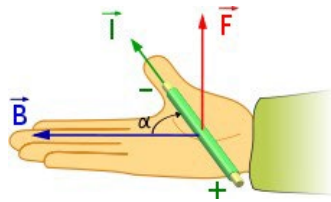

*Wikimedia Commons*  
*B = magnetic field; I = current; F = force*

**Figure 5.36** Right-Hand Rule [Fair Use]

*Right-hand rule for a current-carrying wire in a magnetic field B.*

Given the above structure, when a current passes through the copper sheet, furthermore, around the rectangular assembly from one side of the capacitor to its other side, then on all of its four sides, Lorentz forces are generated. What is more, they are all oriented in the same direction, as revealed in Figure 5.37 below.

As a result, for the duration of the current, this closed system self-propels with pendulum-like motion. So in this scenario,  $F = ma$  in one direction does not have a corresponding  $F = ma$  in the other direction.

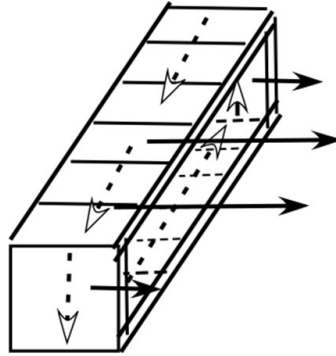

**Figure 5.37** Direction of the Lorentz Forces

*North magnetic field inside of rectangle.*

*South magnetic field outside of rectangle.*

*The hollow dotted arrows represent the direction of the current within the copper sheet. The solid black arrows portray the directions of all resultant Lorentz forces. Observe, they are all oriented in the same direction. The capacitor is not shown.*

In fact, regarding this experiment, there are only two variables. The first is an outward-directed north-to-south magnetic field lines. The other is the current located in the copper sheet oriented perpendicular to the outward north-to-south magnetic field lines. Their interaction produces Lorentz forces which are all oriented at a right angle to both of the variables as above. See Figure 5.37 above. Discern, the resultant Lorentz forces are all oriented in the same direction. There are no other factors involved.

This description is somewhat analogous to segment b of the homopolar motor, whereby the current and magnetic field lines interact at right angles relative to one another, as depicted in Figure 5.38 below.

There is one more caveat: the internal capacitor's current must be oriented in the same direction as the current located within the copper sheet.

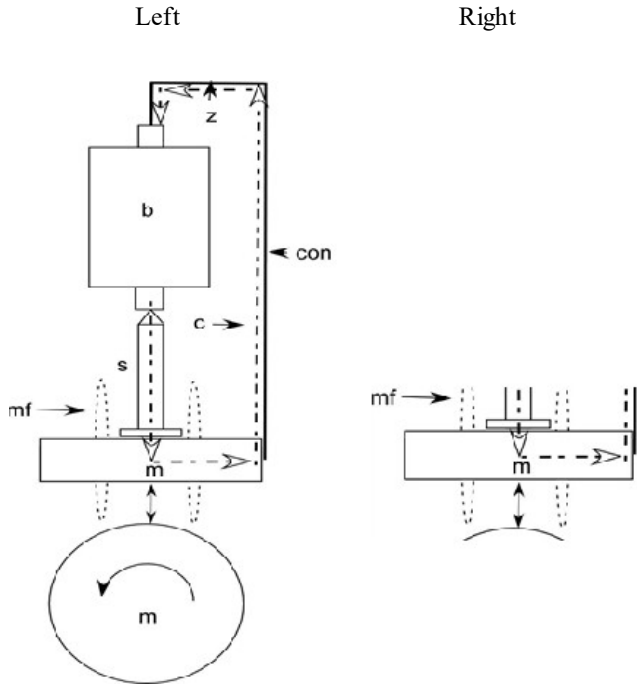

**Figure 5.38** Right Side is Segment b of Homopolar Motor on the Left

Left side is an overall schematic of a homopolar motor as previously illustrated. Right side shows that specific section of a homopolar motor where the current and magnetic field interact at a right angle labeled as segment b Figure 5.26. Their interaction produces a Lorentz force, which then initiates rotation.

Now, in the scenario of the rectangle (not shown), moreover, to some extent analogous to segment b, four of these segments are assembled to form a rectangle. Observe in this setting, the resultant Lorentz forces are then all oriented in the same linear direction (Figure 5.37).

This hypothetical experiment cannot be explained using the laws of modern-day physics. It violates Newton’s third law. However, it can be understood presupposing the current induces a magnetic field, the latter of which is actually a modification of the ether. Subsequently, this modified ether (magnetic field) then interacts, at a right angle, with its own current by way of the Lorentz force, thereby producing propulsion without a propellant. In other words, the current pushes against **the ether**.

#### 5.4.2 The Railgun, a Hypothetical Thought Model of the Theory of Electromagnetic Propulsion without a Propellant

Railguns, in contrast to artillery, depending upon on how they are constructed, can exhibit a reduction in recoil. Now, if the railgun possesses a classic breech, there is equal recoil, but if not, then there is a reduction. This later consequence in and of itself is a violation of Newton’s third law.

Given the presupposition as above, then a railgun properly constructed should be able to self-propel an object, in violation of Newton's third law. In order to clarify this conception, knowledge of a closed versus an open system is paramount.

For instance, a rocket located in outer space uses a propellant for propulsion. So,  $F = ma$  in one direction is equal to  $F = ma$  in the other direction. This is an example of an open system. In addition, a solar sail can capture the solar wind, then use it to propel a spacecraft, somewhat analogous to the wind used as the driving force for a sailboat. Again, this is an open system.

In contrast, as defined by the author, a closed propulsion system is a localized collection of matter (object) and energy that self-propels without either matter or energy leaving or entering the system. In the following paragraphs, two different scenarios of closed systems are presented, the latter of which demonstrates linear propulsion devoid of a propellant.

To start, picture in your mind a hollow cube or box that is stationary with respect to space (PFSRT). In addition, imagine in its exact center, there is a gun, whereby, by the use of braces or struts, it is attached to the two sidewalls. As a result, when discharged, it produces recoil, not only of itself but also of the entire box. Next, envision that the gun discharges a bullet directly to the center of the back wall, hits it, and then is absorbed.

Presuppose, for simplicity, that the absorption process does not reduce the force exerted upon the wall as a function of the bullet's momentum, what is more, presume no atmosphere. The device, just explained, is shown below in Figure 5.39.

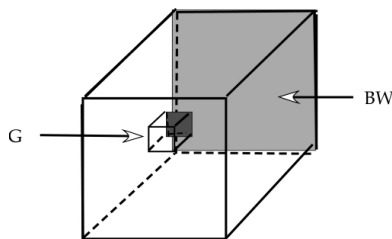

Gun with bullet located at the exact center of box. Fixed attachments not shown = G

Back wall = BW

Box free floating in outer space outside a gravitational field, flat space (PFSRT)

**Figure 5.39** Classic Gun/Railgun Inside a Hollow Box

*Figure 5.39 portrays a hollow cube/box sited in stationary outer space (PFSRT). In addition, it contains a gun, or alternatively a railgun (not shown), attached by struts (not shown) to its exact center.*

*Subsequently, the gun/railgun discharges/accelerates the bullet/projectile, moreover, directly to the exact center of the gray back wall.*

Referring to the following illustration, two scenarios are posed. Scenario 1 depicts a classic gun →with← recoil, whereas Scenario 2 involves a railgun →without← recoil. The hollow cube's different motions/position relative to space (ether of PFSRT) are rendered as shown.

**Scenario 1 - Classic Gun** (with recoil)

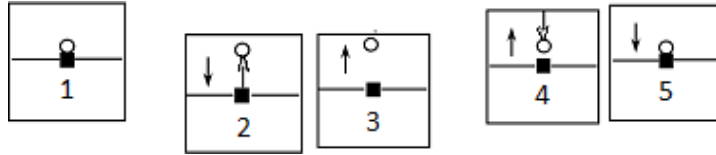

**Figure 5.40** Firing Sequence of Classic Gun

1. The hollow square is a 2D representation of a 3D hollow cube or box.
2. The small solid black square positioned at the exact center of the box represents the gun.
3. The hollow circle denotes the bullet or projectile.
4. The solid horizontal black lines are side struts, which hold the gun in place.
5. The hollow-tipped vertical arrow indicates the direction of the bullet or projectile when fired/accelerated.
6. The solid black vertical arrow denotes the direction of force, oriented either towards the top of the page (+force) or else the reverse force towards the bottom of the page (-force).
7. The position of the hollow square with regard to the top and bottom of the page portrays its position relative to the space of PFSRT.

→Listed below in numerical order, moreover, in written form, is the sequence of events, 1 through 5 which correlates with the numbers in Figure 5.40←.

1. Initial orientation.
2. The gun discharges the bullet, which then produces a reverse force/momentum/time/distance upon the gun/box but only for the duration of the flight of the bullet.
3. Next, when the bullet strikes the back wall with forward force, the momentum/distance/time of 2 then ceases. So, at that occurrence,  $+F = ma$  in one direction equals  $-F = ma$  in the other direction (2 and 3).
4. After that, the hypothetical return of bullet off the back wall towards the gun creates an equal forward force/momentum/time/distance with respect to 2.
5. Finally, when the bullet hypothetically returns to the gun, moreover, stops with reverse force, the above momentum/time/distance of 4 then ceases, (again,  $+F = ma$  in one direction equals  $-F = ma$  in the opposite direction (4 and 5).
6. Referring to Scenario 1, there are two forward forces/momentum/time/distance and two reverse forces/momentum/time/distance all of which are equal but opposite in direction. (3, 4 and 2, 5).
7. Therefore, in the final analysis, concerning the cube's position relative to the space 1 (PFSRT), 1 and 5 are equivalent.
8. Take note, after all of the above, the box has returned to its original position relative to the space of PFSRT.

See Figure 5.40 above. When the bullet is discharged (2), there is a reverse force (recoil) exerted on the gun ( $F = ma$ ). In addition, since the gun is attached to the box by struts, both obtain momentum directed towards the bottom of the page, moreover, traverse a distance over time. However, this momentum only transpires during the flight of the bullet. Next, as the bullet strikes the back wall with equal force ( $F = ma$ ) (3), the previous induced momentum of the

box/gun ceases. This is because, at this point,  $+F = ma$  in one direction equals  $-F = ma$  in the other direction. There has indeed been motion of the box relative to space (PFSRT). Nevertheless, take note, the center of gravity of this closed system has been altered.

After that, if by some magic, the bullet could be projected with an equal force ( $+F = ma$ ) from the back wall (4), furthermore, returned to the gun's chamber ( $-F = ma$ ), as it was just before being fired (5), then both the center of gravity and position of the box/gun, relative to the space of PFSRT, will have returned to their original positions (5).

In other words, when the bullet returns to the gun, again  $+F = ma$  in one direction (4) equals  $-F = ma$  in the other direction (5).

This is a reversal of (2) and (3). Given that there are two forward forces, which correspond with two equal reverse forces, the box then returns to its original position with reference to the space of PFSRT.

The author points out this caveat. The two sets of opposing forces do not necessarily have to be equal; nevertheless, by including the function of time, the box will still return to its original position.

What Scenario 1 illustrates, referring to a closed system of this kind, whereby Newton's third law still applies, is this One can linearly move an object without a propellant relative to space, though only minimally, moreover, with a corresponding shift in its center of gravity. However, regarding translational motion, one cannot propel it without a repellent for a considerable distance.

### Scenario 2 - Railgun (without recoil)

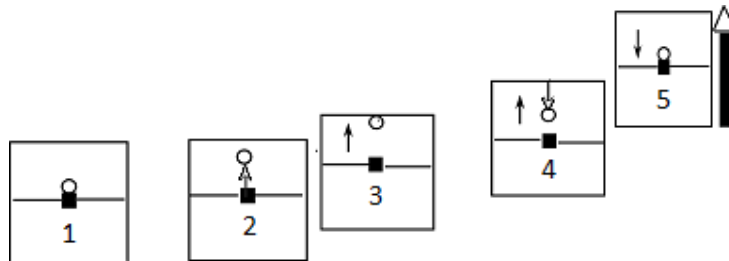

**Figure 5.41** Firing Sequence of Railgun without Recoil (no breech)

1. Initial orientation.
2. The railgun accelerates the projectile; however, there is no recoil force exerted on railgun/box during the time of the flight of the projectile. As a result, the box remains stationary, again during the flight of the projectile.
3. The projectile strikes the back wall, which then produces a forward force/momentum/time/distance on the box ( $F = ma$ ).
4. Next, the return of projectile off the back wall, without the use of a railgun, produces, again, a forward force/momentum/time/distance on the box ( $F = ma$ ).
5. Then, when the projectile returns to the railgun, its motion ceases. This function then produces a reverse force/momentum/time on the railgun/box ( $-F = ma$ ).
6. Take note, there are two forward forces/momentums/times (3, 4) but only one reverse force momentum/time (5). Therefore, there is an imbalance.
7. For this reason, there is then a residual forward momentum/time/distance directed towards the top of the page as depicted by the large vertical black arrow associated with 5.

See Figure 5.41 above. What transpires with the use of a railgun that exhibits reduced or absent recoil compared to a classic gun? Keep in mind, a railgun properly constructed intrinsically violates Newton's third law. For that reason, Scenario 1 does not apply.

Vis-à-vis Scenario 2: Presuppose everything is identical compared to Scenario 1, except in this setting, a railgun rather than a classic gun is used. With reduced recoil, the description is very complex, but the underlying principles of physics are identical to absent recoil. So, for sake of simplicity, presume no recoil.

With regard to Scenario 2, at time (1), all is equivalent to Scenario 1. However, at time 2, when the railgun accelerates the projectile, there is then no recoil force. As a result, the railgun/box remains immobile relative to space (PSRT) but only during the time of the flight of the accelerated object.

Subsequently, when the projectile strikes the back wall (3), there is a forward force ( $+F = ma$ ) exerted on the wall, producing momentum/time/distance. Consequently, the box/railgun propels in the direction of motion of the accelerated object. Additionally, analogous to Scenario 1, the center of gravity has now changed.

One could, as in Scenario 1, return the projectile from the back wall to its origin  $\rightarrow$  without the use of a railgun  $\leftarrow$ , therefore producing an equal force ( $+F = ma$ ) (4) and reverse force ( $-F = ma$ ) (5). This dual function would also shift the center of gravity back to its original configuration.

Here is the crucial concept to acknowledge. Unlike Scenario 1, there are now two forward forces ( $+F = ma$ ) and only one reverse force ( $-F = ma$ ). Therefore, as a result of this imbalance, there remains a residual forward momentum of the box/railgun oriented towards the top of the page (large vertical black arrow next to box 5). Consequently, there is then continuous translational momentum of a closed system without the use of propellant.

What is more, one could repeat the same process and again accelerate the box by using the railgun, then again, and again, and so on, and so forth. This repetitive function would propel the box/railgun through space devoid of a propellant.

Remember that the opposite forces do not necessarily have to be equal; nevertheless, by including the function of time, the results are the same—residual momentum.

$\rightarrow$  Classic modern-day physics posits that a closed system cannot exert a net force upon itself  $\leftarrow$ . Nevertheless, Scenario 2 hypothetically proves this assumption is false.

With reference to this second scenario, the most important concept to take home is that this type of railgun does not have perceived recoil; the author emphasizes "perceived." This is because it actually pushes or repels against the ether. And we do not "see" the ether with our eyes or with any of the other senses. In fact, modern-day physics presupposes it does not even exist.

However, presuming there is an ether, which functions as a part of the equal and opposite force as just hypothesized, then Newton's third law could still be correct, but not in the context in which he originally described it.

### 5.4.3 Propulsion of the Railgun; a Practical Device of Electrometric Propulsion without a Propellant

For the nonscientist, before reading this section, once again, reviewing the website given below would be helpful. <http://bit.ly/2aCjS5A>

This example is discussed in greater detail in Appendix F. Therefore, after reading this section, a review of that appendix might be beneficial.



As noted in the prior section, specifically Example 2, Scenario 2, the hypothetical device offered is not a practical device. Alternately, conceivably, this third example is. If one peruses the available literature, there are numerous articles which posit that the principles of physics attributed to a railgun are consistent with Newton's third law. However, other research papers postulate that if there is no breech, then the recoil of a railgun can be markedly reduced or even absent. If this is indeed true, then this fact alone is irreconcilable with Newton's third law.

In order to grasp the function of a railgun of this latter type (no breech), once again the recognition of these two principles of physics is paramount. The first is the production of a magnetic field by a current (Figure 5.42). And the second is the Lorentz force produced by the interaction of a current with a magnetic field (Figure 5.43). Both are presented below.

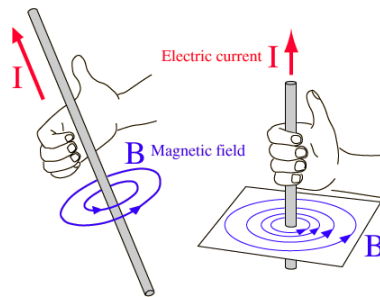

Wikimedia Commons

**Figure 5.42** Magnetic Field and Lorentz Force Caused by Current [Fair Use]

*Orientation of magnetic field relative to the direction of +current.*

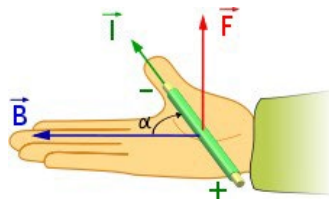

Wikimedia Commons

$B =$  magnetic field;  $I =$  current;  $F =$  force

**Figure 5.43** Magnetic Field and Lorentz Force Caused by Positive Current [Fair Use]

- Right-hand rule for a current-carrying wire in a magnetic field  $B$ .
- Orientation of Lorentz force with respect to the direction of the +current as well as of the magnetic field.
- The Lorentz force is oriented at a right angle with respect to both the current and magnetic field.

Railgun Without a Breech (no recoil). The abstract, picture, figures, and discussion presented below are of an actual experimental device built for a master's thesis written by Matthew K. Schroeder at the Naval Postgraduate School, Monterey, California. The thesis is titled *An Investigation of the Static Force Balance of a Model Railgun* by Matthew K. Schroeder, June 2007. That article can be found at <http://bit.ly/2aPSfaI>.

### Abstract of Thesis

*An interesting debate in railgun research circles is the location, magnitude, and cause of recoil forces, equal and opposite to the launched projectile. The various claims do not appear to be supported by direct experimental observation. The goal of this research paper is to develop an experiment to observe the balance of forces in a model railgun in a static state. By mechanically isolating the electrically coupled components of such a model, it has been possible to record the reaction force on the rails and compare that force with the theoretical force on a projectile. The research is ongoing, but we have observed that the magnitude of the force on the armature is at least seventy times greater than any predicted equal and opposite reaction force on the rails.*

Figures 5.44 and 5.45 portrayed below are schematics of this device.

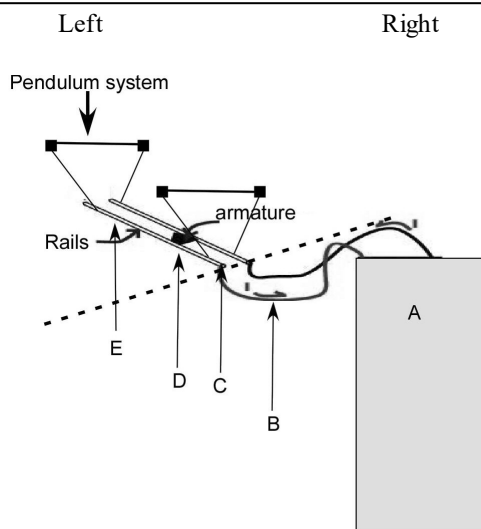

**Figure 5.44** Schematic of Railgun

*A = batteries, capacitors, copper wires, etc., which complete the circuit*

*B = copper wire conductor which delivers current to the rails. The adjacent parallel wire receives current from the rails*

*C = freely movable copper brush attachments that connect copper wire conductors to the rails*

*D = armature*

*E = rails*

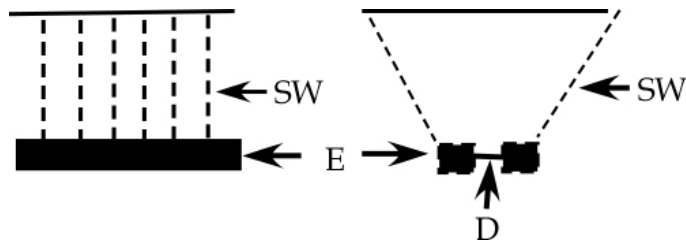

**Figure 5.45** Pendulum System Suspended by Wire Cables (SW)

*Images above are to the left of the dotted line of C in Figure 5.44.*

See figures 5.44 and 5.45. Matthew K. Schroeder, et al, suspended an armature and two rails (E) with the use of wire cables (SW). Therefore, analogous to a pendulum, the railgun could freely swing back and forth. Next, by employing copper brushes (C), afferent and efferent copper wires, (B and adjacent parallel wire), which deliver current to and receive current from the rails, were attached to the apparatus. Brushes were utilized, because in the presence of a current, they still allowed the device to freely swing back and forth.

In addition, in one overall configuration the armature was able to independently move relative to the fixed rails and vice versa. In another arrangement, they were physically attached to one another. Furthermore, in the presence of a current, relative motion of the different components was observed and measured. What is more, there were pressure-sensitive devices that calculated the Lorentz forces generated regarding three different scenarios. These three experiments are listed below.

### Experiments

1. The rails are fixed, and the armature is free to move.
2. The armature is fixed, and the rails are free to move.
3. The armature and rails are physically attached to each other, and the entire rail could freely swing back and forth just like a pendulum.

**Results** The following are the observed experimental results, using the same numerical values as listed above.

1. The rails remained stationary as they are fixed. The armature accelerated forward relative to the rails.
2. The armature remained motionless, since it is fixed. Even so, there was no reverse force accelerating the rails backwards; the rails remained immobile as well.
3. Both the rails and armature, which are physically attached to each other, rocked forward (accelerated) similar to a pendulum.

So what do these series of experiments demonstrate? They prove that when the armature is accelerated by force, relative to the rails, there is no reverse force exerted on the rails (1 and 2). In addition, when the entire railgun accelerated forward with pendulum-like motion, there is no perceived reverse force exerted on anything (3).

Now, concerning Scenario 3: that outcome cannot be explained by using the known laws of physics as it violates Newton's third law. In contrast, it can be understood with the presumption of an ether. And here is the rationale.

Described below is the functionality of Experiment 3. During the induction of the current, the magnetic field lines produced are greater inside the railgun compared to its outside. So, as these field lines interact with their own current, this effect produces net Lorentz forces accel-

erating the armature forward. In turn, it drags the attached rails along with its own motion. In addition, there are other symmetrical Lorentz forces attempting to split the rails apart. Nevertheless, the parallel rails are fixed to each other, so they cannot separate. Furthermore, there is no current located at the breach, as it is open. Consequently, there is no reverse breech force. Overall, this leaves only the net Lorentz forces accelerating armature forward, along with its attached rails. So what does the armature push against? —**The Ether**.

For reinforcement: here again are the explanations for experiments 1, 2, and 3, but now including pictorial form, using this basic model.

**1. The rails are fixed, and the armature is free to move.** (See Figure 5.46 below.)

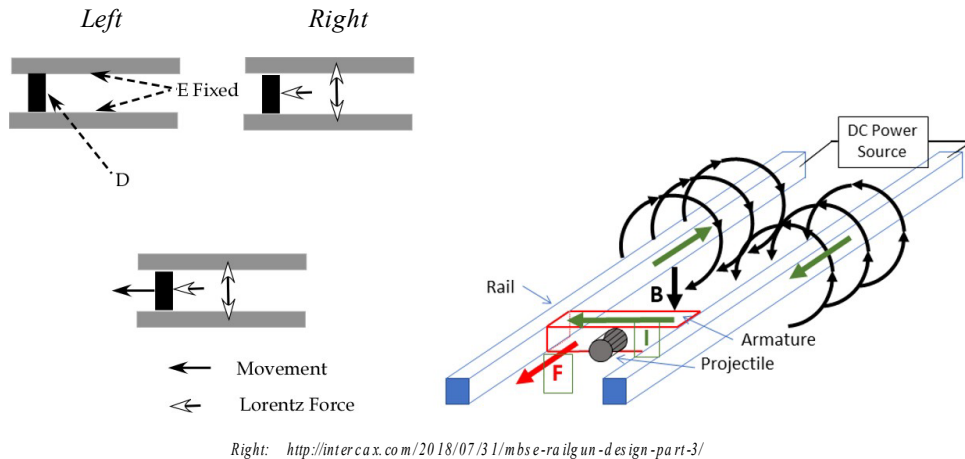
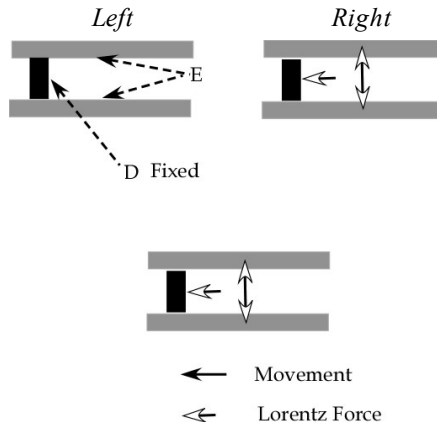

**Figure 5.46** Rail Structure is Fixed; Armature Moves [Fair Use]

- Top left D = armature, E = rails
- Top right = Lorentz forces
- Bottom = direction of movement

- A. The armature is accelerated forward by force since everything else is fixed.
- B. In addition, there are net forces exerted on the rails that are attempting to split them apart. Nevertheless, they are fixed to one another; as such, they cannot separate. In other words, those forces are blocked.
- C. There is no Lorentz force at the open breech, because there is no physical breech.
- D. →In summary, only the armature propels forward←.

**2. The armature is fixed, and the rails are free to move.** (See Figure 5.47 below.)

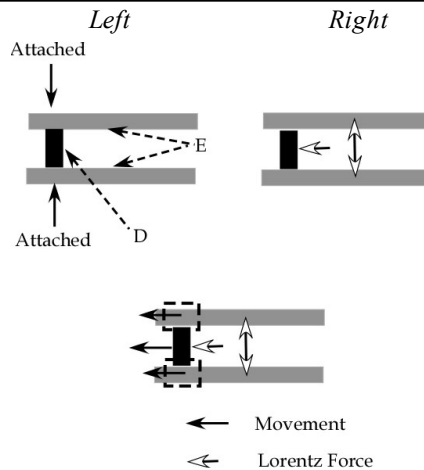

**Figure 5.47** Armature is Fixed; Rails Do Not Move

- Top left  $D = \text{armature}, E = \text{rails}$
- Top right = Lorentz forces
- Bottom = no movement

- A. The armature is fixed. Therefore, it cannot be accelerated forward.  
 B. In addition, there are net forces exerted on the rails that are attempting to split them apart. Nevertheless, they are fixed to one another, as such, they cannot separate. Those forces are blocked.  
 C. Most importantly, there is no reverse back force exerted on the rails relative to the armature. In addition, there is no force located at the breech, because there is no breech.  
 D. →In summary, the entire device remains immobile←.

**3. The armature and rails are physically attached to one another; moreover, the entire railgun is free to rock back and forth, just like a pendulum.** (See Figure 5.48 below.)



**Figure 5.48** Armature and Rails Move Together like a Pendulum

- Top left  $D = \text{armature}, E = \text{rails}$
- Top right = Lorentz forces
- Bottom = direction of movement
- Squares depict the physical attachments of the rails and armature

A. There is a forward net Lorentz force exerted on only the armature, which then drags the rails along with its own motion.

B. In addition, there are other net forces attempting to split the rails apart. However, they are fixed relative to one another, so they cannot separate.

C. Furthermore, relative to the armature, there is no reverse force accelerating the rails backwards.

D. What is more, no reverse force is present at the breech, because, at that location, there is no current so no breech. In essence, at that location, there is nothing for the field lines to interact with.

E. →Given all of the above, the entire railgun swings forward with pendulum-like motion←.

Now, regarding Scenario 3: Since the entire railgun rocks forward, what is it pushing against to produce an equal and opposite reaction? The answer is, again, **the ether**.

However, this interpretation may not be germane, because this device may, in fact, contain a breech. This is because during the time the railgun propels forward from force, the generator, the afferent and efferent wires, etc. could be associated with a reverse force. If this is indeed the case, there could be an equal and opposite reaction. So, in order to solve this dilemma, the following hypothetical thought experiment is proposed as revealed in Figure 5.49 below.

Presuppose a railgun is positioned in outer space with its armature physically attached to the two attached/fixed parallel rails, furthermore, containing an open breech. At the position of the breech, located between the two rails, a linear capacitor is positioned such that it spans the breech's entire length. In addition, the capacitor is constructed such that the opposite charges are separated by a large space, again equivalent to the width of the breech. The entire apparatus is a fixed rectangle with a capacitor positioned at the breech.

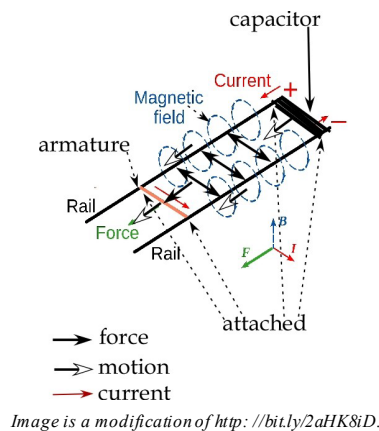

**Figure 5.49** [Fair Use]

*Scenario 3 in outer space (ether) with a capacitor located at its breech.*

- There is a capacitor located at the breech with its opposing charges separated by a distance equivalent to the width of the breech. For that reason, there is no current at the breech. When the current

is switched on, it then interacts with its own induced magnetic field to produce the net Lorentz force as portrayed above.

- Given that the rails are fixed to each other, they do not separate. However, as shown, the armature is propelled forward by force. In addition, since the armature is physically attached to the entire railgun, it then drags it along with its own accelerated motion. Observe there is no reverse force exerted on the rails relative to the armature. And also note that there is no reverse force at the breech, as there is no current at that location.

As a result, when the device is activated, the electron current then flows through the attached rails and armature. But no current is present at the breech. For that reason, analogous to Example 3 (figures 5.48 and 5.50), the entire railgun with its attached capacitor propels forward absent a propellant. However, unlike Explanation 3, this is a definite closed system, exhibiting significant translational propulsion without a propellant, therefore, in violation of Newton's third law.

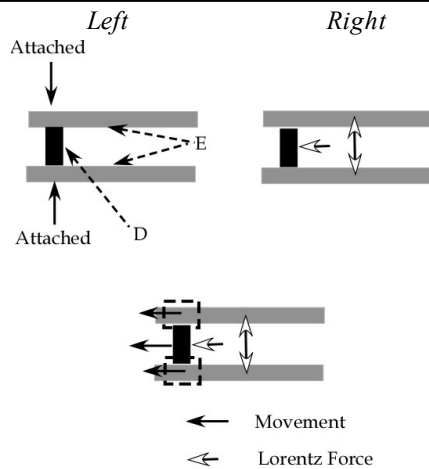
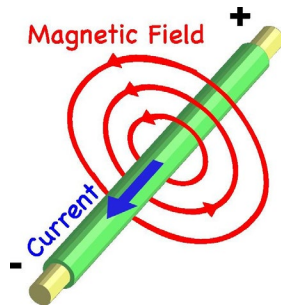

Figure 5.50 A Repeat of Figure 5.48

#### 5.4.4 Propulsion of the Ring

For the nonscientist, before reading this section, once again viewing this website would be helpful. <http://bit.ly/2aCjS5A>. This hypothetical device is clarified in much greater detail in Appendix G. The dissertation presented below is a brief synopsis of that explanation. In order to comprehend this device, one must accept these two basic principles of physics.

- Once again, an electric current located within a linear conductor produces a circular magnetic field as shown in Figure 5.51.



<http://commons.wikipedia.org/wiki/file:Electromagnetism.svg>

**Figure 5.51** Positive Current Producing a Magnetic Field [Fair Use]

When current ( $I$ ) goes through a wire, it produces a magnetic field ( $B$ ) around the wire. The field is oriented according to the right-hand grip rule. An electron current would be a left-hand rule—the opposite orientation.

2. That induced field, then interacts with its own current to produce Lorentz forces, oriented at a right angle relative to both the direction of the magnetic field and the current, as shown in Figure 5.52.

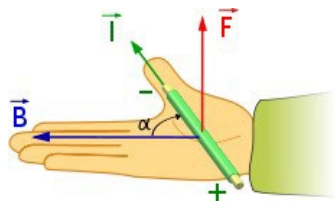

Wikipedia

$B =$  magnetic field;  $I =$  current;  $F =$  force

**Figure 5.52** Right-Hand Rule [Fair Use]

*Right-hand rule for a positive current-carrying wire in a magnetic field  $B$ .*

*Orientation of Lorentz force with respect to the direction of the current, as well as of the magnetic field.*

The intention of this section is to posit a theory of electromagnetic propulsion based upon an electric current, a magnetic field, as well as directed magnetic pulses (EMP). It is fundamentally a very simple concept based upon these three assumptions.

1. A current within a wire conductor induces a magnetic field, not only surrounding the wire but within the substance of the wire as well.
2. Subsequently, that portion of the magnetic field which is located  $\rightarrow$ within the wire $\leftarrow$  interacts with its own current, again  $\rightarrow$ within the wire $\leftarrow$ , to produce Lorentz forces, once more  $\rightarrow$ within the wire $\leftarrow$ .
3. By means of magnetic flux compression technology, one can project a powerful directed magnetic pulse in a specific direction, analogous to a gun.

These three assumptions will be used to posit a hypothetical electromagnetic propulsion device. Due to the complex three-dimensional nature of this concept, it is considerably easier to explain this model if one uses diagrams. For that reason, five diagrams will be presented.



Each diagram will present a concept that will lead to the next diagram, until finally, the concept of electro-magnetic propulsion is explained. The five diagrams are listed below.

1. A single straight wire conductor with a current.
2. Two straight wire conductors with both currents flowing in the same direction.
3. Two straight wire conductors with their currents flowing in opposite directions.
4. A single circular wire conductor (ring) with a current.
5. A single circular (loop) conductor (ring) with a current, along with its induced magnetic field. The latter of which, relative to the plane of the ring, is distorted on one side by a directed magnetic pulse. For that reason, there is electromagnetic propulsion. Below are the five diagrams with explanations.

They describe, as well as illustrate, electromagnetic propulsion without the use of a propellant.

(1) **See Figure 5.53 below** illustrating a single straight wire conductor with its current flowing into the page. The wire with its current induces a circular magnetic field, not only surrounding the wire but also within its own substance. Subsequently, that portion of the magnetic field, which is located within the body of the wire, then interacts with its own current to produce the Lorentz forces as depicted in Figure 5.53. Notice, both the density of the magnetic flux and the direction of the Lorentz forces, are symmetric with respect to the wire's diameter.

Furthermore, the Lorentz forces are oriented symmetrically in a circle towards its center. This process produces electromagnetic propulsive forces. Nevertheless, due to the above symmetry, these forces are balanced. As a consequence, there is no motion or propulsion. On the other hand, if these forces were somehow asymmetrical rather than symmetrical, there would be propulsion. Nonetheless, this is not the case.

In this and subsequent diagrams, the overall Lorentz forces will be divided into separate vector forces relative to the X (+x,-x) and Y (+y,-y) axes and additionally, with respect to the later figures in the Z axis. For example, in this Figure 5.53, the Lorentz forces counteract each other in both the X and Y axes. However, in reality, all the Lorentz forces are oriented symmetrically in a pattern of a circle towards the wire's center.

As such, they again neutralize each other. In both instances, there is no propulsion as these forces are balanced. The two scenarios are analogous to each other. The author has chosen this method of explanation, so one can easily envision the concepts. Otherwise, the diagrams and description will be too complex to comprehend.

Alternatively, if the conductor is curved or angled (Figure 5.54), the Lorentz forces are asymmetrical, being greater within the conductor with respect to its concave side compared to the convex side. Therefore, when a current is present, moreover, if the wire is free to unfold, the conductor straightens out. The question then is: While in the process of unbending or straightening out, what is the conductor pushing against to do so? Effectively, this is electromagnetic propulsion without a propellant. It violates Newton's third law.

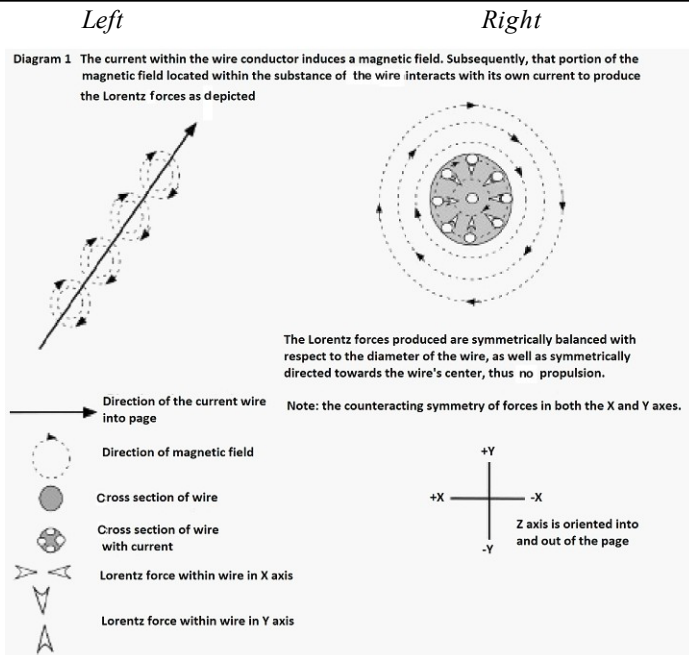

**Figure 5.53** Magnetic Field Inside the Wire Produces Symmetrical Lorentz Force

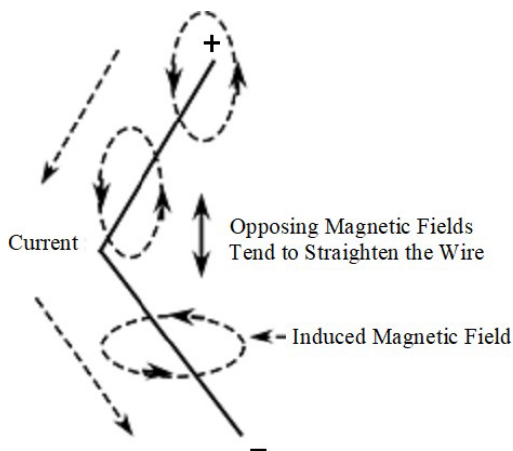

**Figure 5.54** Right-Angle Bend Produces Asymmetrical Lorentz Force

*A wire with a perpendicular bend will have an increasingly strong moment to straighten with an increasing magnitude of applied current.*

*However, once the conductor straightens, the Lorentz forces are, at that time, symmetrical relative to the axis of the wire, so no further movement is observed.*

(2) See Figure 5.55 below that depicts two straight wire conductors with both currents flowing into the page. Each separate wire, with its current, induces its own magnetic field, not merely surrounding itself, but also within its own substance.

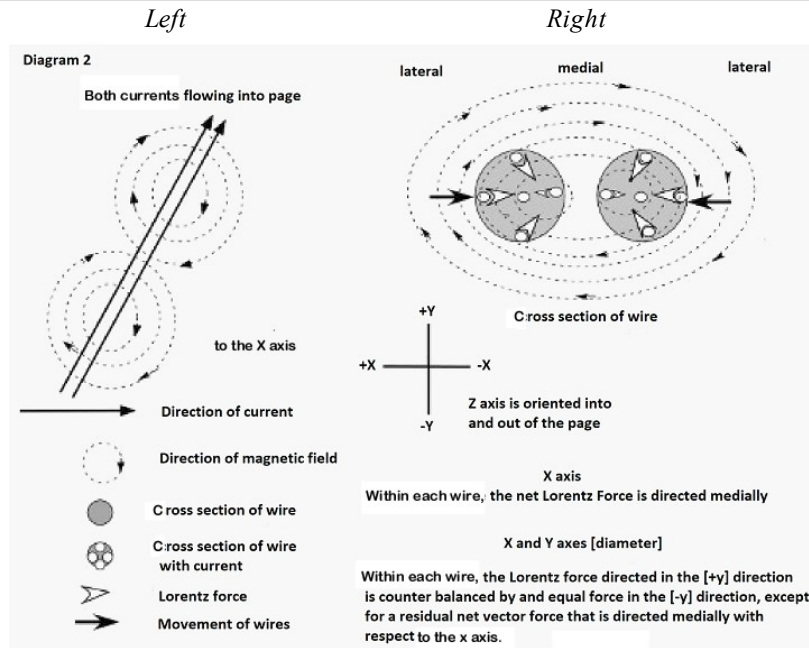

Figure 5.55 Combined Magnetic Fields Cause Attraction

As illustrated in Figure 5.55, the two magnetic fields interact to create one overall modified field.

Subsequently, that portion of this one modified field, which is located within the body of each wire, interacts with the current in that same wire to produce the Lorentz forces as illustrated. Notice, with respect to each wire, the density of the magnetic flux in the X axis (+x versus -x directions) is asymmetrical, moreover, greater laterally compared to medially. As a result, the →net← Lorentz force that is directed medially is greater compared to the force which is directed laterally.

And, relative to each wire, the density of the magnetic flux takes the form of a mirror-image symmetrical pattern, in the X and Y axes (diameter) relative the X axis.

Consequently, the resulting Lorentz forces neutralize one another, except for a residual vector directed medially.

Therefore, overall, relative to each wire, the direction of the →net← Lorentz force is medial, and as a result, the wires propel towards each other. This process is actually electromagnetic propulsion, nevertheless impractical, given that once the wires are in contact, all motion ceases. Make a note, outside the substance of the wires in the region of the interacting magnetic fields, there is no force. Forces are located only within the body of the wires, where the one modified magnetic field interacts with each of the two currents.

(3) See Figure 5.56 below which illustrates two straight wire conductors with opposing currents. The left current is flowing out of the page, whereas the right current is flowing into the page. Each current induces its own magnetic field, not only surrounding itself but within its

own substance as well. The two magnetic fields interact and form two separate modified fields, as depicted in Figure 5.56.

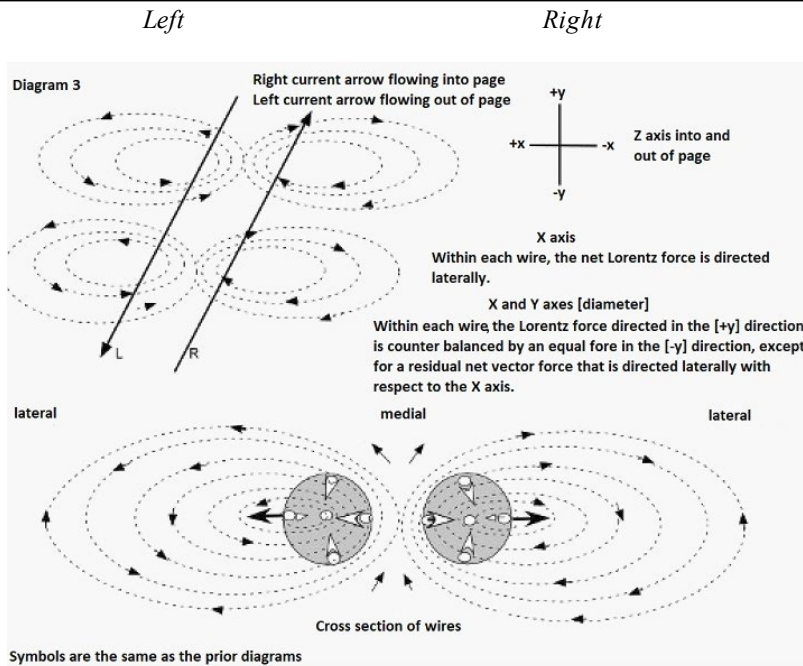

**Figure 5.56** Opposing Magnetic Fields Cause Repulsion

Subsequently, that portion of each modified field, which is located within the body of its own wire, interacts with its own current, again in the wire, to produce the Lorentz forces as illustrated. Notice, relative to each wire, the density of the magnetic flux in the X axis (+x and -x directions) is asymmetrical, moreover, greater medially compared to laterally. Therefore, the →net← Lorentz force that is directed laterally is greater compared to the force which is directed medially.

Observe as well, relative to each wire, that the density of the magnetic flux takes the form of a mirror image symmetrical pattern, in the X and Y axes (diameter) relative to the X axis. Therefore, overall, the Lorentz forces neutralize each other, except for a residual vector directed laterally.

Consequently, with respect to each wire, the direction of the →net← Lorentz force is lateral; as such, the wires propel away from each other. Once again, outside the substance of the wires in the region of the interacting magnetic fields, there is no force. Force is located only within the body of each wire, where the current within that wire interacts with its own associated modified magnetic field. This process is electromagnetic propulsion, though again, impractical, since once the wires travel a given distance from each other, the two magnetic fields will cease to interact. Subsequently, each will transform into a single wire as depicted in Figure 5.53. Nevertheless, the two wires possess residual momentum.

(4) See **Figure 5.57** below which illustrates a current in a single circular (loop) conductor. In future deliberations, this structure will be defined as the ring. The shape of the magnetic field created by this current is equivalent to the classical magnetic field induced by a loop current, as depicted in Figure 5.57.

The ring with its current produces a magnetic field not just surrounding itself, but also within its own essence. Subsequently, that portion of the magnetic field, which is located within the body of the ring, interacts with its own current, again, within the wire, to produce the Lorentz forces as depicted.

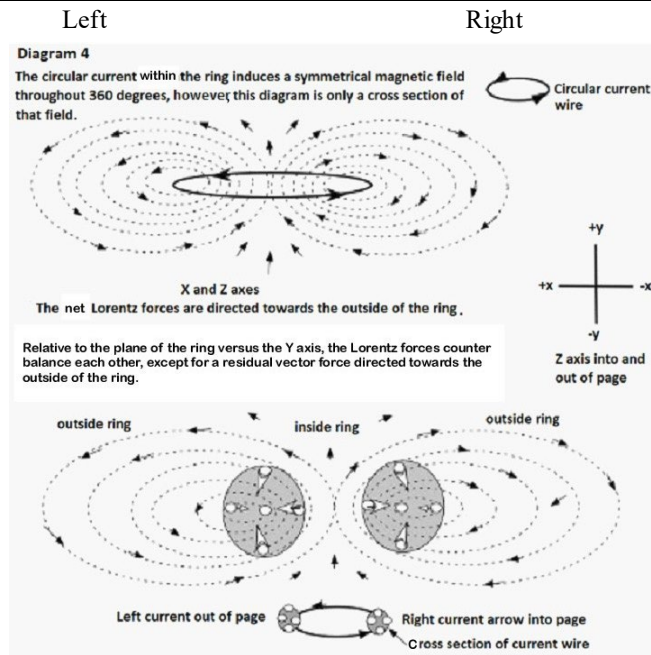

**Figure 5.57** Magnetic Field of Ring Causes No Movement

Notice, relative to the plane of the ring (X and Z axes), the density of the magnetic flux is asymmetrical, moreover, greater within the inner side of the ring compared to its outer side. Therefore, throughout 360 degrees, the Lorentz forces that are directed towards the outside of the ring are greater compared to those forces which are directed towards its inside.

Discern as well, relative to the plane of the ring versus the Y axis, the density of the magnetic flux, within the ring, takes the form of a mirror image symmetrical pattern. Therefore, throughout 360 degrees, the Lorentz forces neutralize each other, except for a residual vector, directed towards the outside of the ring.

Observe, with respect to the plane of the ring, the overall  $\rightarrow$ net $\leftarrow$  Lorentz forces are directed symmetrically and equally outward, throughout its circumference. Nevertheless, the ring is a physically intact structure; accordingly, it blocks these forces.

Essentially, all the Lorentz forces produced within the ring are either blocked by its solid structure, or they neutralize one another. As such, there are no unbalanced forces.

Consequently, as previously depicted in Figure 5.53, there is, a gain, no propulsion. Alternatively, if the Lorentz forces were somehow asymmetrical with respect to the plane of the ring, there would be propulsion. Commit this last concept to memory.

(5) **See Figure 5.58 below.** In order to comprehend this last and crucial diagram, one must appreciate the concept of magnetic flux compression producers. This apparatus produces an extremely powerful **directed** magnetic pulse, which can be used as a military weapon, analogous to a gun. However, in this situation, it produces electromagnetic propulsion.

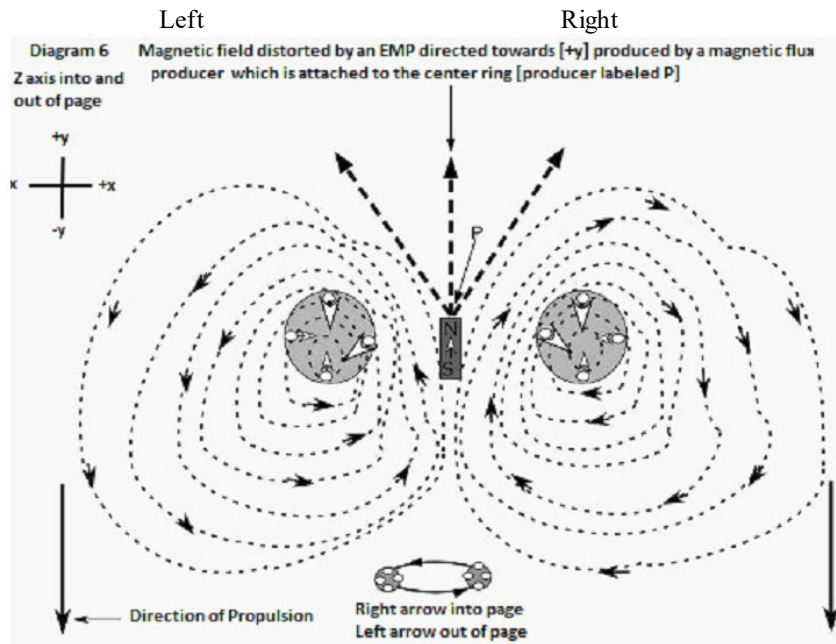

Figure 5.58 Magnetic Flux Compression Causes Propulsion

Recall in Figure 5.57, that relative to the plane of the ring, (X and Z axes), the  $\rightarrow$ net $\leftarrow$  Lorentz forces are directed, throughout its circumference, towards the outside of the ring. Nevertheless, the ring remains intact. As a consequence, there is no propulsion. Recollect as well, relative to the plane of the ring, versus the Y axis (throughout the ring), there is mirror-image symmetry of the Lorentz forces. As a result, they neutralize one another, with the exception of a residual vector, oriented towards the outside of the ring, again blocked by its intact structure. So, overall, there is no propulsion.

Fundamentally, with reference to Figure 5.57, there are electromagnetic propulsive forces produced within the ring; nevertheless, they are either blocked by its intact structure, or they counteract one another. Essentially, there are no unbalanced forces and so, no propulsion.

Now, imagine that from an attached magnetic flux compression producer located at the ring's exact center, that a single symmetrical magnetic pulse is emitted (Figure 5.58). Additionally, assume the pulse is directed axially towards one side, moreover, relative to the plane of the ring ( $+y$ ). Therefore, for an extremely brief period of time, this pulse will symmetrically distort the shape of the magnetic field on that side. The other side may change symmetrically as well, but the two halves are asymmetrical with respect to each other.

Thus, with respect to the plane of the ring versus the Y axis, the mirror-image symmetry previously depicted in Figure 5.57 is lost, as now depicted in Figure 5.58.

Observe, at this instant in time, relative to the plane of the ring, there are symmetrical  $\rightarrow$ net $\leftarrow$  vector forces, throughout its circumference, directed towards the outside of the ring, which are neutralized by its intact structure. However, most importantly, there are now other  $\rightarrow$ net $\leftarrow$  vector forces throughout its circumference directed towards the bottom of the page ( $-y$ ) that are not neutralized. Given that these latter forces are unbalanced, with respect to the Y axis, there is electromagnetic propulsion towards the bottom of the page.

All five of the electromagnetic propulsion figures presented in this section are more easily understood if one assumes the existence of an ether. So let's explain this assertion.

Fundamentally, the current creates a magnetic field. The magnetic field is a modification of the ether. For that reason, when the current and the modified ether interact, they push against one another at a right angle, so during each pulse, there will be electromagnetic propulsion of the ring towards the bottom of the page (-y).

### Summary

A single circular loop conductor (ring) with its current induces a magnetic field, not only surrounding the ring but also within the substance of the ring. Subsequently, that portion of the magnetic field, which is located within the body of the ring, interacts with its own current to produce Lorentz forces.

Electromagnetic propulsive forces are produced from this process. However, these forces are either blocked by the intact structure of the ring, or they are symmetrically oriented in opposing directions. As such, these latter forces counteract each other. Essentially, all the forces are balanced, and consequently, there is no propulsion of the ring.

However, if the magnetic field, relative to one side of the plane of the ring is symmetrically distorted by a directed magnetic pulse, then for the duration of this pulse, there will be Lorentz forces within the ring, some of which are not blocked by its physical structure, nor annulled by opposing symmetrical forces. Accordingly, these forces are unbalanced. As a result, there will be electromagnetic propulsion of the ring along its axis depicted by the long downward vertical solid arrows in Figure 5.58.

This function results in propulsion without a typically defined propellant. So, according to this new conception, the current and the ether push against one another at a right angle, and this interaction is the equal and opposite reaction. This is not exactly Newton's theory, but close. In the author's opinion, the major reason why these forms of propulsion devices are never even considered is that without the presumption of the ether, concepts like those just described do not even enter our minds. And if they do, they are rejected, because they violate the supposed irrefutable laws of physics.

Therefore, these so-called "laws" have confined us into a closed dark box. As a result, our thinking and creativity become restricted.

Alternately, if all these devices work as advertised, then it is time to totally rewrite physics. Moreover, in the future, if we do so, let us not close and seal the box. In other words, to pursue reality, keep the box open, and let the light of truth shine in.

## 5.5 The Permanent Magnetic Motors

The framework of this subdivision is as follows:

5.5.1 The Merging of Electromagnetism with Permanent Magnetism

5.5.2 The Circular Permanent Magnetic Motor

5.5.3 The Shielded Permanent Magnetic Motor

### 5.5.1 The Merging of Electromagnetism with Permanent Magnetism.

A review of the classic physics of electro-magnetism is presented in the following website.  
<http://bit.ly/1xOBK5N>

Before explaining these two different types of permanent magnetic motors, first, the underlying physics of electromagnets (EM) and permanent magnets (PM) are examined. As with the rest of this publication, these explanations differ from accepted theories, moreover, are quite

lengthy. Nevertheless, the descriptions are necessary, if one wishes to understand these devices. To introduce the theory, first a series of five seemingly disparate physics concepts are presented.

However, after proceeding, one will eventually come to realize that they are, in fact, inter-related with one another, what is more, how ultimately, they are weaved together to explain the function of these two types of novel motors. So, to begin, here is the outline, then the explanation of the five concepts.

1. Solenoid / Electromagnet (EM)
2. Earth's Magnetic Field
3. Permanent Magnet (PM)
  - a. Classic Theory of the Physics of a PM
  - b. Alternative Theory of the Physics of a PM
4. The Internal Lorentz Forces of Both a PM and an EM
  - a. Internal Lorentz Forces of a Solitary EM
  - b. Internal Lorentz Forces of Single PM
5. Interacting PMs

Later on in this chapter, these concepts will be used to explain the function of these two types of motors.

### **(1) Solenoid / Electromagnet (EM)**

For a video review of the classic explanation of the production the magnetic field of a solenoid, see the website cited below:

*<http://bit.ly/1xOBK5N> from 9 minutes to 19 minutes 15 seconds.*

For future reference, regarding this chapter, the terms solenoid and an electromagnet (EM) are assumed to be synonymous. Now, please refer to Figure 5.59, moreover, the following caption and discussion.



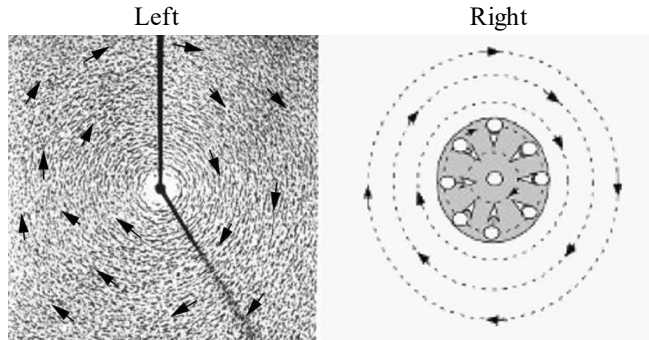

Wikimedia Commons

**Figure 5.59** A Straight Wire Conductor [Fair Use]

- The picture to the left shows the external magnetic field induced by a straight wire conductor painted by iron filings.
- The schematic to the right demonstrates that the magnetic field generated by the current not only surrounds the conductor wire but also exists within its own substance.
- The hollow-tipped arrows on the right depict the direction of the Lorentz forces located within the wire, as a function of the current interacting with its own induced magnetic field.

A straight wire conductor containing a current produces a circular magnetic field, not only surrounding the wire but also within its own substance. The induced magnetic field then interacts with its own current,  $\rightarrow$ within the conductor $\leftarrow$ , to generate Lorentz forces, moreover, all oriented symmetrically towards the wire's center as revealed in Figure 5.59 above.

See Figure 5.60 below. Now, if the very same conductor is made into a solenoid, the configuration of its magnetic field is that of a classic dipole with a north and south pole. Again, there are Lorentz forces generated as with the straight wire conductor, but they are more complex and will be discussed later in this chapter.

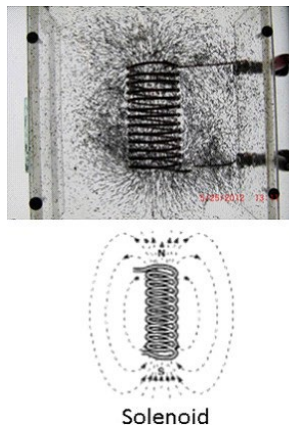

Solenoid

Top: University of Michigan - Bottom: Hyperphysics

**Figure 5.60** Electromagnet with its Magnetic Field [Fair Use]

**(2) Earth’s Magnetic Field**

For a video review of the classic explanation of the production of the Earth’s magnetic field, see the website cited below:

<http://bit.ly/1xOBK5N> from 0 to 9 minutes 15 seconds.

Now refer to figures 5.61 and 5.62, as well as the following explanation.

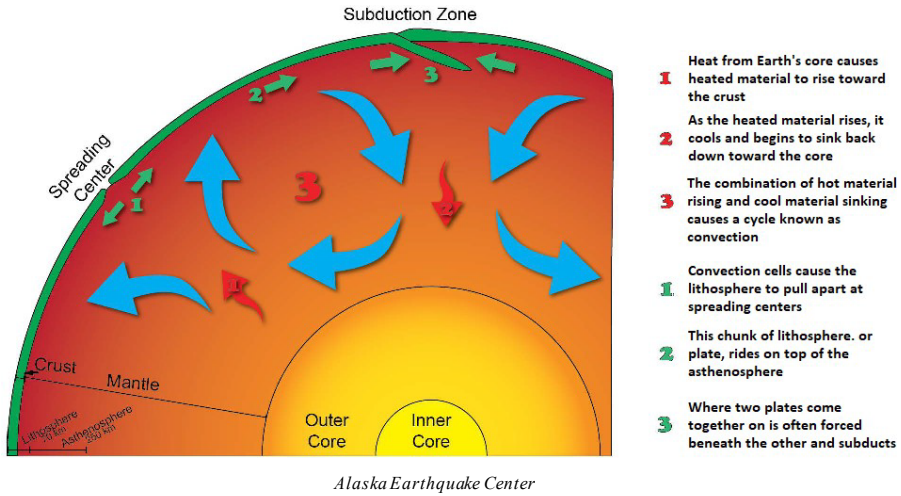

**Figure 5.61** Convection Currents in Earth [Fair Use]

*In Earth’s mantle, convection currents, as shown above, transfer large amounts of heat. Heat from the core and the mantle itself causes electric convection currents in the mantle. These convection currents cause the Earth’s magnetic field. [Source for caption only: <http://bit.ly/2b2Pjfbf> ]*

## The Earth as a Magnet

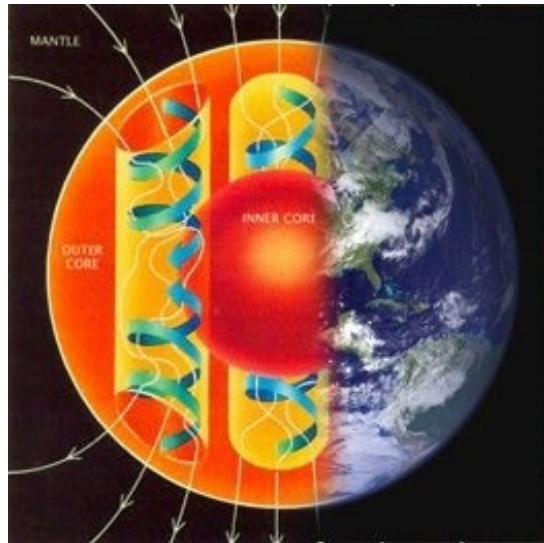

*kjmagnetics.com*

**Figure 5.62** Dynamo Mechanism [Fair Use]

*Illustration of the dynamo mechanism that creates the Earth's magnetic field: convection currents of magma in the Earth's outer core, driven by heat flow from the inner core, organized into rolls by the Coriolis force, creates circulating electric currents, which generate the magnetic field. [Source: *kjmagnetics.com*]*

Purportedly, from the literature, the Earth's magnetic field is formed by the summation of numerous very large, similarly oriented electron convection currents. These are found deep within the Earth's crust, or alternatively, within the outer portion of its molten core.

So, as portrayed in figures 5.61 and 5.62 above, moreover, Figure 5.63 below, the generation of the Earth's magnetic field is analogous to multiple extremely large solenoid electromagnets, the sum of which then produces the Earth's overall dipole field.

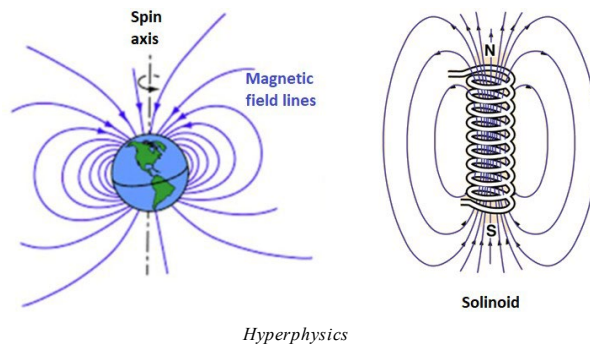

**Figure 5.63** Magnetic Field of the Earth and the Electromagnet [Fair Use]

*As illustrated above, the production of Earth's magnetic field and the induction of the magnetic field by a solenoid are produced in exactly the same manner.*

### (3) Permanent Magnet (PM)

Please refer to figures 5.64 and 5.65 as depicted below, furthermore, the following explanation. Observe that the overall configuration of the dipole magnetic field of a solenoid and the dipole of a PM appears to be identical. The following paragraphs will explain the rationale as for the reason why.

#### (a) Classical Theory of the Physics of a PM

Compared to a solenoid, the production of the magnetic field of a permanent magnet now labeled (PM) is posited to involve a completely different mechanism. The standard theory presupposes that within the substance of a PM, the unpaired outer shell electrons are all aligned in exactly the same direction. Additionally, since each unpaired electron is a small dipole, the summation of all similarly aligned unpaired dipoles produces the overall PM's magnetic field. Furthermore, all other randomly oriented dipole electrons, located within the PM's substance, counteract and therefore, neutralize one other.

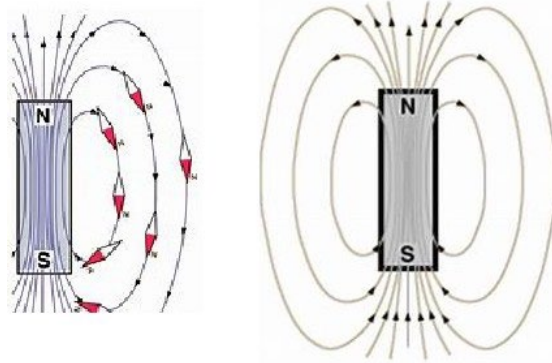

Hyperphysics

**Figure 5.64** Dipole of a Bar Magnet [Fair Use]

*The schematics portrayed above in Figure 5.64 demonstrate that the dipole of a bar magnet in this figure is analogous to the dipole of a solenoid in Figure 5.65 below.*

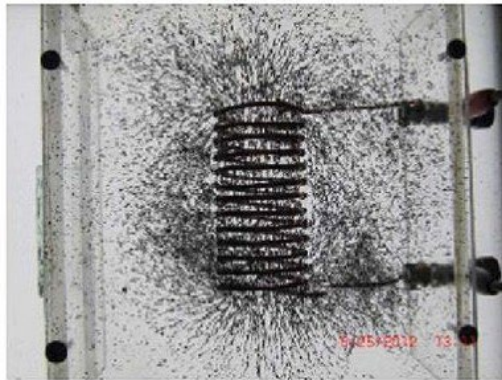

University of Michigan

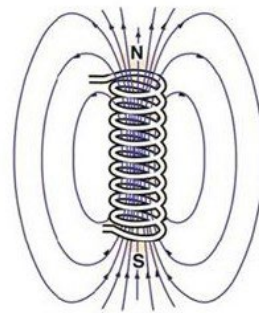

Solenoid

Hyperphysics

**Figure 5.65** Dipole of an Electromagnet [Fair Use]

*The schematics and the photo portrayed above in figures 5.64 and 5.65 demonstrate again that the dipole of an electromagnet (lower) is analogous to the dipole of a PM (upper).*

Nevertheless, all is not clear-cut. As it turns out, the overall magnetic field of a PM is a product of numerous microscopic subunits called magnetic domains. Refer to Figure 5.66.

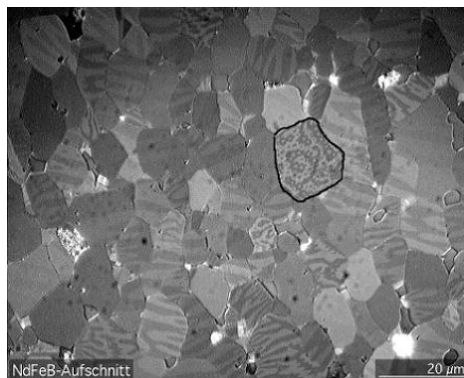

Wikipedia

**Figure 5.66** Grains of NdFeB with the Magnetic Domains [Fair Use]

*Pictured above are several grains of NdFeB with the magnetic domains made visible via contrast with a Kerr microscope. [Source: Wikipedia]*

Fundamentally, each domain corresponds to a small EM possessing a north and south pole. In addition, the magnetic fields produced by all of the individual domains combine to form one overall dipole-shaped field. This is the PM's overall magnetic field.

The domains of a PM are, by and large, fixed in a given direction; therefore, there is a stable overall magnetic field. Alternatively, within a ferromagnet (FM), they are oriented in a specific direction, only in the presence of an externally applied magnetic field. However, if this field is removed, then over time, the alignments diverge, moreover, become random. For that reason, the ferromagnet loses its overall magnetic field.

Please refer to Figure 5.67 below and the following discussion.

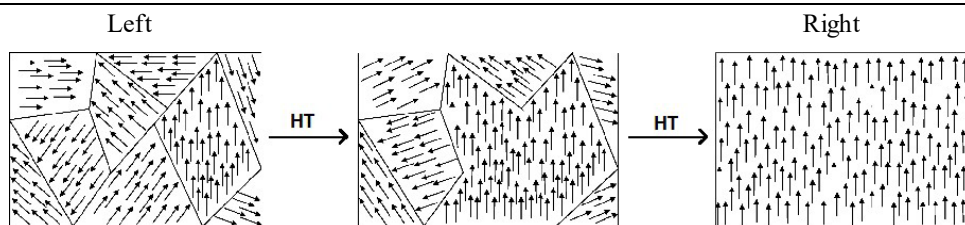

Wikipedia

**Figure 5.67** Increasing Magnetic Field Increases Magnetic Domains [Fair Use]

The domains of a ferromagnet are not fixed structures, given that they are malleable. For instance, an individual domain consists of similarly aligned unpaired outer shell electrons. Moreover, under the influence of an external magnetic field, each domain can incorporate into its own structure additional electrons, thus grows physically larger. Simultaneously, the domains reorient their poles, so that they are aligned along with the axis of the externally applied magnetic field.

This function is depicted in Figure 5.67 above. The blocks of arrows correspond to the domains. Notice, as the externally applied field increases from left to right, the domains grow

progressively larger and, moreover, concurrently, they increasingly become oriented along the same magnetic axis as compared to the external applied field.

Conversely, with the loss of influence of an external field (right to left), they lose electrons, thus become physically smaller, and at the same time, assume a more random orientation.

**(b) An Alternative Theory of the Physics of a PM**

The overall magnetic field of a solitary PM is a dipole, furthermore, made from the summation of all the individual domains of that magnet. Therefore, by logic, there are only two options.

The first is within each domain, the magnetic field is a function of similarly aligned outer-shell unpaired electrons. And for the second, within each domain, the field represents similarly aligned "solenoid-like" circular electron currents. If this dichotomy is not the case, then what other option is there?

→For that reason, this new theory posits that the domains of a ferromagnet (FM) as well as of a PM are comprised of "crystal-like groups" of unpaired outer-shell electrons traveling in a circumferential pattern analogous to a solenoid←. And so, with respect to an FM, just like the standard theory, these circular currents can add or lose electrons depending upon external influences. Therefore, they can change their size, shape, and orientation under the influence of an externally applied magnetic field or from the presence of other adjacent domains.

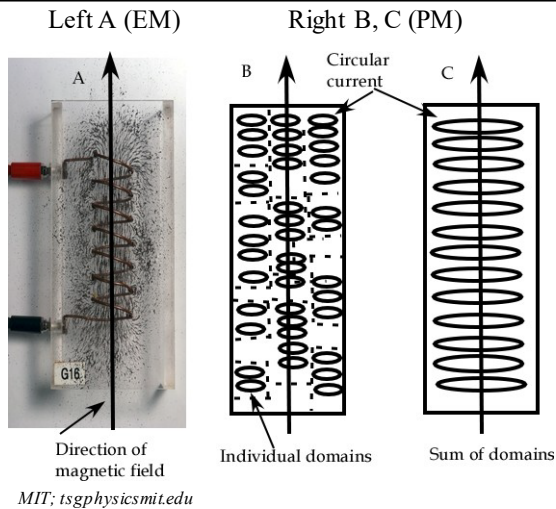

**Figure 5.68** Electromagnet (EM) Permanent magnet (PM) [Fair Use]

In contrast, compared to an FM, the crystal-like circular currents located within the domains of a PM are generally fixed in a given direction. Even so, under the influence of a very strong external magnetic field, they behave somewhat analogous to an FM. Nevertheless, in contrast to an FM, when the very intense external field is removed, the PM's intrinsically generated magnetic field resumes its original shape.

Refer now to Figure 5.68 and the following discussion. As portrayed in Figure 5.68, this alternative model posits that the domains of a PM are actually stacks of parallel superconducting circular electron currents, (B in Figure 5.68) to some extent analogous to a solenoid, (A in Figure 5.68). In essence, the sum of the circular currents of B then produces the PM's overall magnetic field (C in Figure 5.68). This transformation from B to C is analogous to the gen-

eration of the overall magnetic field of the Earth as a product of summation of its individual electron convection eddy currents.

Now refer to Figure 5.69 below.

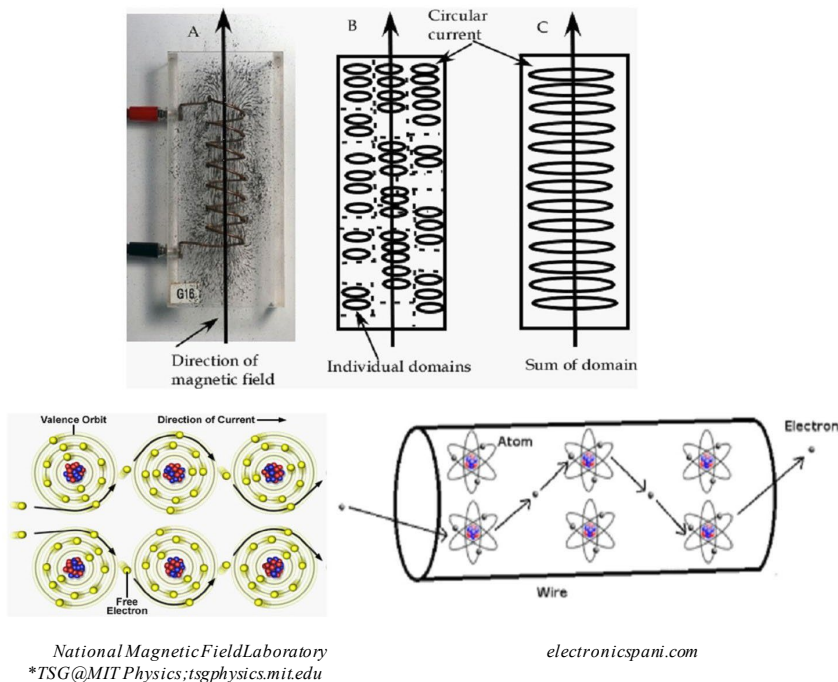

**Figure 5.69** Electrons Moving from Atom to Atom [Fair Use]

The two side-by-side images directly above demonstrate outer-shell electrons traveling from one atom to the next adjacent atom and so on. →This is a net current since the electron orbit the nuclei very rapidly but travel from atom to atom very slowly←.

Explained with greater detail, this new theory (Figure 5.69) hypothesizes that within each domain, the outer-shell unpaired electrons, travel from one atom (neodymium) to the next adjacent atom, moreover, in a circumferential pattern, accordingly, creating a circular electron current. The individual circular elements are stacked one on top of another; (B in figures 5.68 and 5.69) just as multiple permanent ring magnets will intrinsically stack, assuming similarly aligned poles. The sum total of all these individual domains then produces the PM’s overall magnetic field (C in figures 5.68 and 5.69).

In summary, and again for emphasis, each domain of a PM consists of stacks of parallel superconducting circular electron currents, somewhat analogous to a solenoid. In addition, most of the domains are oriented permanently along the same axis. As a result, there is a persistent, generalized, overall magnetic field, defined in classical terms, as a PM with a dipole.

So what evidence is there which indicates that this postulate is correct? Listed below are two observations which provide support for that idea.



### First Observation

The outer-shell electron structures of both a PM (neodymium) and a metal conductor, such as copper are very similar. For instance, the best metal conductors possess unpaired outer-shell electrons, comparable to a PM (neodymium). Therefore, within the metal conductor, or else on its surface, the outer-shell electrons sequentially travel from one atom to an adjacent atom and so on. Likewise, this new theory posits that the same function also occurs within the domains of a PM. However, the main dissimilarities are first, the electron current within a metal conductor travels linearly, whereas the electron current of the PM travels in a circular pattern limited by the walls of its own domain. In addition, the current within the metal conductor requires a voltage, whereby the current, located within the domain of a PM, must be superconducting, given that it is persistent, devoid of input of energy (voltage), moreover, with no production of heat.

To recap, the resemblance of the outer-shell electron structures of both a PM and a metal conductor leads credence to this new postulate, for comparable electron arrangements should correlate to similar electron functions.

### Second Observation

In order to provide further evidence, the following five magnetic field images are presented. They illustrate that the physical appearance of the magnetic field produced within a permalloy (permanent magnet) is analogous to the appearance of a magnetic field generated by a solenoid. The list of images to be offered is as below.

- Image 1. A permalloy (permanent magnet)
- Image 2. A straight-wire conductor
- Image 3. A wire loop conductor
- Image 4. A permanent magnet
- Image 5. A solenoid

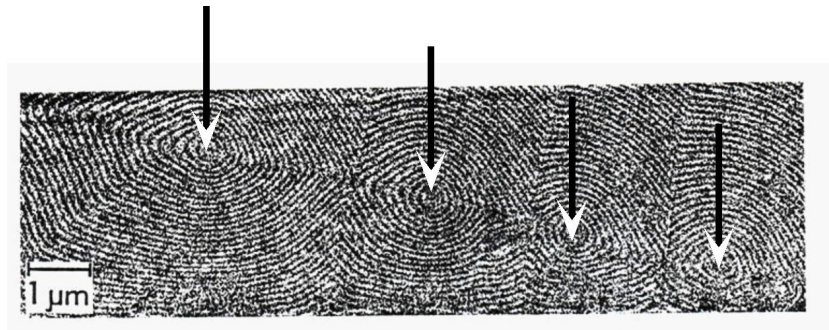

Akira Tonomura

**Figure 5.70** Image 1 - A permalloy (Permanent Magnet) [Fair Use]

- This image depicts the appearance of a magnetic field located within a permalloy painted by electrons. The image is from the book *The Quantum World Unveiled by Electron Waves* by Akira Tonomura, (Page 77); the image is copyrighted.
- The author's interpretation as to what this photo represents does not correspond with the assertions presented within that article.

Image 1 in Figure 5.70 above shows the shape of the magnetic field located within a permalloy. A permalloy is analogous to a PM. Observe, there are multiple adjacent circumferential-shaped magnetic field lines, each of which surrounds a central core (see arrows).

Image 2 in Figure 5.71 below depicts a straight wire conductor, containing a current, furthermore, the configuration of its magnetic field. Observe, Image 2 is analogous to the individual circular sub-units in Image 1 (PM).

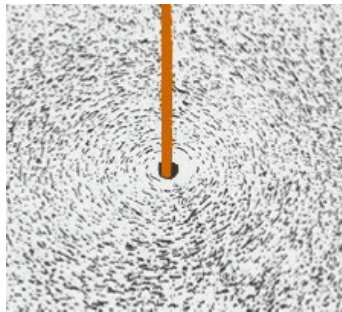

School for Champions, Ron Curtus:

[https://www.school-for-champions.com/science/magnetic\\_field\\_moving\\_charges.htm#.X4stV2WofzI](https://www.school-for-champions.com/science/magnetic_field_moving_charges.htm#.X4stV2WofzI)

**Figure 5.71** Image 2 - A straight wire conductor [Fair Use]

*Image 2 illustrates the shape of a magnetic field painted by iron filings produced by a current located within a straight wire conductor.*

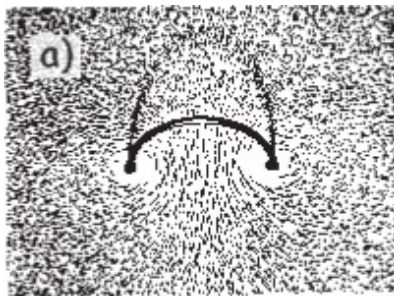

Semantics Scholar: [https://www.semanticscholar.org/paper/Magnetic-augmented-rotation-system-\(MARS\)-and-Liu/96e8416b2b79ed998f09aa7b6fdccd6690b82284/figure/3](https://www.semanticscholar.org/paper/Magnetic-augmented-rotation-system-(MARS)-and-Liu/96e8416b2b79ed998f09aa7b6fdccd6690b82284/figure/3)

**Figure 5.72** Image 3 - A Wire-loop Conductor [Fair Use]

*Image 3 illustrates the configuration of the magnetic field painted by iron filings induced by a wire-loop conductor with a current.*

Image 3 above illustrates the shape of the magnetic field produced by an electron current in a wire loop conductor. Once again, observe the similarity of this Image 3 compared to Image 1 (PM), whereby there are multiple circular magnetic fields located side by side, each of which surrounds a central core.

The two photos (images 4 and 5 in Figure 5.73 below) illustrate the shape of a PM's magnetic field (left) and the configuration of the magnetic field of a solenoid (right). Take note of the similarity.

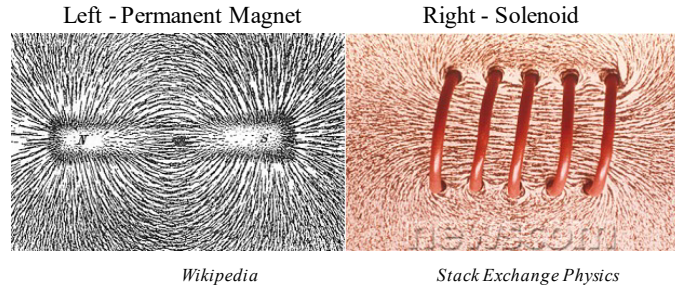

**Figure 5.73** Permanent Magnet and Solenoid [Fair Use]

- *Image 4 (left) depicts the dipole (field) of a PM painted by iron filings.*
- *Image 5 (right) demonstrates the dipole (field) of a solenoid painted by iron filings.*

In summary, given the fact that the outer shell electron structures of an electromagnet, as well as a PM, are analogous, and the observation that the shape of the magnetic field of a permalloy and a solenoid both consist of concentric circles, side by side, each surrounding a central core, offers credence to the conclusion that the magnetic field of a PM is generated in the exact same manner as an EM. What is more, it is very difficult to explain just how the magnetic field of a PM can appear as illustrated in Image 1 (PM) by using only the classical, moreover, accepted electron dipole theory. To further delve into this magnetic field correspondence, now imagine a longitudinal cross section of a solenoid as portrayed in Figure 5.74.

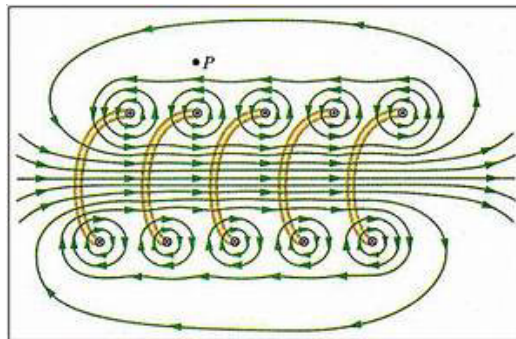

**Figure 5.74** Magnetic Field of a Solenoid [Fair Use]

*The image imparted above is the cross-sectional appearance of the magnetic field produced by a solenoid.*

See figures 5.74 above and 5.75 below. Additionally, pertaining to a solenoid, picture in your mind a cross-section of the individual wires, with their currents, moreover, associated magnetic fields, as shown in the two images, figures 5.74 above and 5.75 below. If so, then one would envisage multiple circumferential shaped magnetic fields, located side by side, each surrounding a central wire or the core.

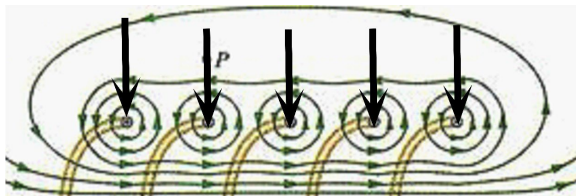

NDC Resource Center

**Figure 5.75** Top Half of an Electromagnet [Fair Use]

Figure 5.75 is the top half of Figure 5.74. Notice the circular magnetic fields located side by side.

Refer to figures 5.76 and 5.77 below, furthermore, the following deliberations. It is important to note that these illustrations are not schematics, rather actual photos of magnetic fields. Figure 5.76 is that of a PM. Figure 5.77 is of a solenoid.

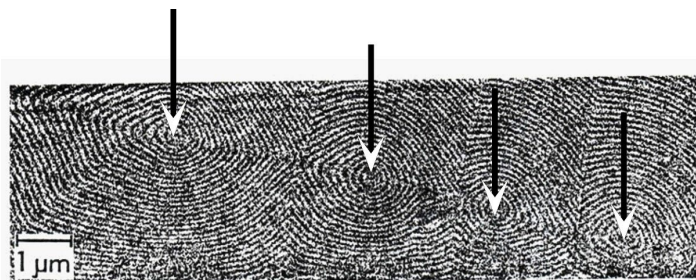

Quantum World by Akira Tonomura

**Figure 5.76** Permanent Magnet [Fair Use]

See figures 5.76 above and 5.77 below. This is crucial. The adjacent circular field patterns surrounding a central core are analogous structures, although one is an electromagnet (Figure 5.77) and the other a PM (Figure 5.76) just like figures 5.70 and 5.75.

So overall, for all the above reasons, this alternate theory posits that each domain of a PM is formed from stacks of superconducting circular electron currents somewhat analogous to a solenoid.



[tsgphysics.mit.edu/front/](http://tsgphysics.mit.edu/front/)

**Figure 5.77** Electromagnet (Solenoid) [Fair Use]

Notice, for both a PM and an EM, there are multiple circular structures containing a central core, located side by side.

Even so, although these two types of magnets are similar, they are not identical. On one hand, with regard to a solenoid, there is only a single spiral wire. On the other hand, with reference to the domains of a PM, the individual circular currents are positioned one on top of the other, analogous to a stack of coins. In addition, in contrast to an EM, a PM's current is persistent, moreover, at room temperature. Therefore, it must be super-conducting, given the fact that there is no input of energy, moreover, no production of heat.

Furthermore, the magnetic field lines located within a PM are significantly entrained, as they must pass through multiple, extremely compact" solenoid-like"-shaped loop currents (domains), which are not only located on top of one another but also positioned closely side by side. For that reason, the magnetic field lines produced within the substance of a PM are not as dispersed compared to that of an EM. This is also because the latter does not trap the field lines as much, as its central core consists mainly of air. Consequently, the appearance of the field lines located within a PM are significantly more compact, or entrained, compared to the open central portion of a solenoid (EM).

#### Overall Conclusion for the Physics of a PM

See figures 5.78 and 5.79 below. The above discussions and illustrations establish that the production of the magnetic field of an electromagnet, the Earth's magnetic field, and the magnetic field of a PM, are all one and the same process. So, assuming that this postulate is correct, the classic dipole electron model for the production of the magnetic field of a PM can be discarded.

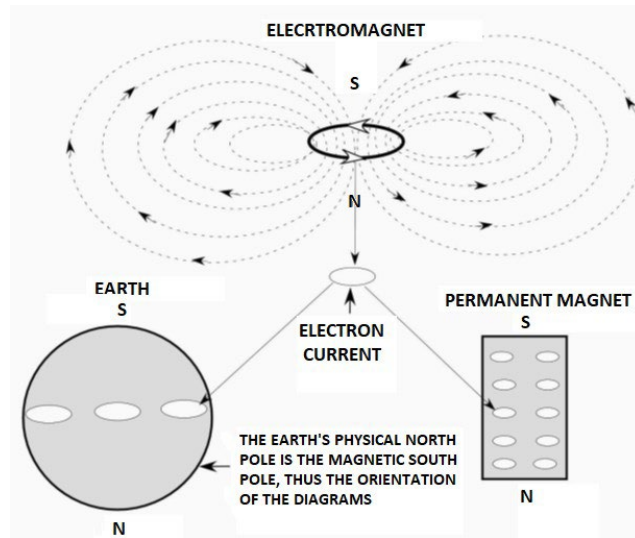

**Figure 5.78** Comparing the Magnetic Field of the Earth, PM, and Electromagnet [Fair Use]

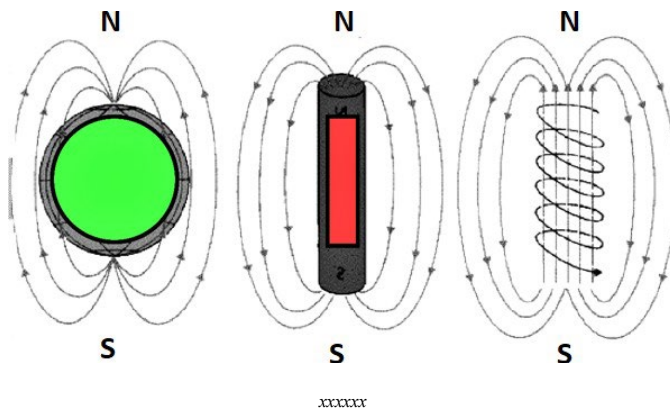
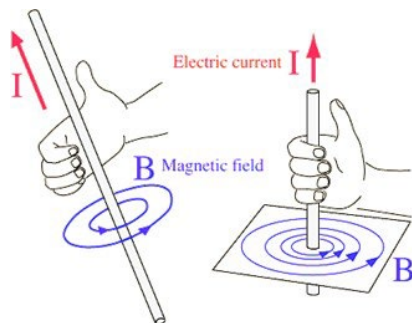

**Figure 5.79** Comparing the Magnetic Field of the Earth, PM, and Electromagnet [Fair Use]

**4. The Internal Lorentz Forces of Both a PM and an EM**

**(a) Internal Lorentz forces of a solitary EM**

Up to this point, this chapter has fairly well established that the underlying principles of the physics of the PM and a solenoid are analogous. Even so, before one can comprehend these two new novel motors, there is still more to clarify. To accomplish this task, first the internal Lorentz forces of an EM will be examined, that being easier to visualize. And once that concept is understood, it can be extrapolated with reference to the function of a PM.



Wikimedia Commons

**Figure 5.80** Orientation of Magnetic Field [Fair Use]

*Figure 5.80 above shows the orientation of a magnetic field produced by a positive current.*

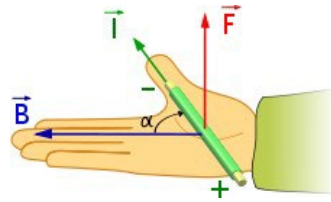

Wikimedia Commons

$B =$  magnetic field;  $I =$  current;  $F =$  force

**Figure 5.81** Direction of the Lorentz Force [Fair Use]

• Figure 5.81 above depicts the orientation of Lorentz force produced by the interaction of a positive current with a magnetic field. Take note, the force is oriented at a right angle relative to both the current and magnetic field.

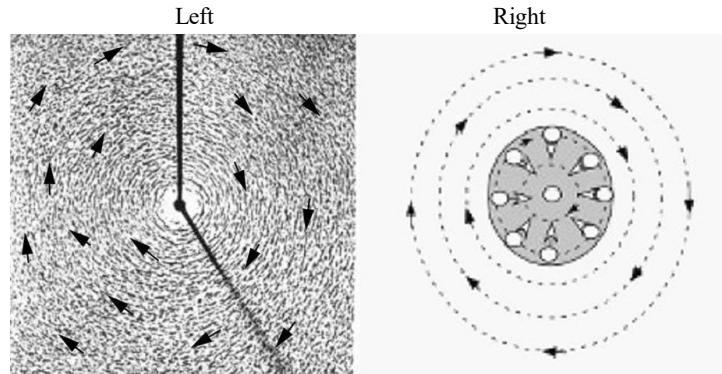

Wikimedia Commons

**Figure 5.82** Hollow Arrows Depict Lorentz Force [Fair Use]

Figure 5.82 (left) is a photo of the magnetic field induced by a straight wire conductor with a current painted by iron filings (left). This is a function of Figure 5.80. Black arrows = direction of magnetic field. In Figure 5.82 (right), the magnetic field then interacts inside the wire with its own current to produce Lorentz forces as portrayed by the hollow arrows (right). This is a function of Figure 5.81.

- Central gray circle (right) = cross section of straight wire conductor.
- Circular dotted lines (right) = magnetic field both outside and inside conductor wire.
- Current is traveling in the longitudinal direction into the page.
- Hollow arrows = symmetrical internal-oriented Lorentz forces located within the conductor.

Refer to figures 5.80, 5.81, and 5.82, moreover, the following dissertations.

As already revealed, a single straight wire conductor produces a circular magnetic field, both inside and outside of the wire (Figure 5.82). That magnetic field then interacts with its own current,  $\rightarrow$ again within the wire $\leftarrow$ , to produce Lorentz forces. Observe that these forces are equal, moreover, inwardly symmetrical relative to the axis of the conductor. In essence, there are propulsive forces present, but as a result of inward symmetry, there is no net force, thus no motion, propulsion, or work.

In the same manner, as regarding a solenoid, the exact same physical process transpires, yet much more difficult to visualize. Now, refer to Figure 5.83 below and the following explanation.

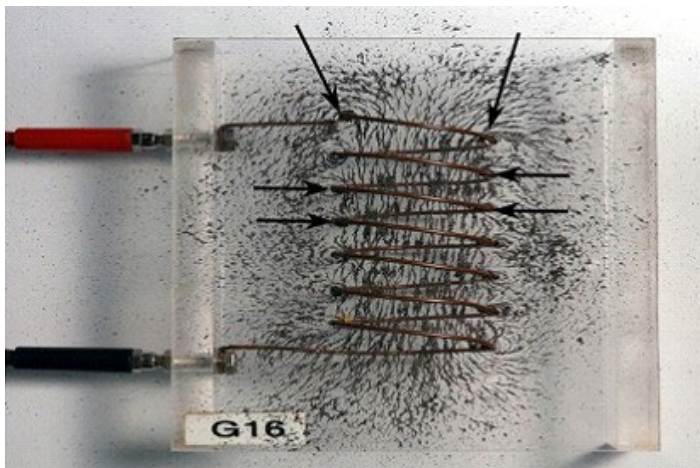

*tsgphysics.mit.edu/front/*

**Figure 5.83** Solenoid with Magnetic Filings and Interaction Points of Current [Fair Use]

Figure 5.83 is a photo of a solenoid with its magnetic field lines painted by iron filings. The black arrows depict the locations where the current intersects with its own generated magnetic field lines, specifically at a right angle.

See Figure 5.83 above. Observe, vis-à-vis to the upper portion of the coil, the current intersects at a right angle with its own induced magnetic field (interaction location depicted by the slanted semi-vertical arrows). In addition, regarding the coil's central part, the intersection of the magnetic field lines and the current are again oriented at right angles (location depicted by the horizontal arrows).

These interactions then create Lorentz forces in the orientations as portrayed in figures 5.84, 5.85, and 5.86 below (hollow arrows).

But first recall:

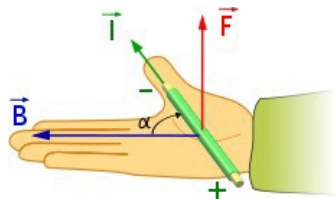

*Wikimedia Commons*

$B = \text{magnetic field}; I = \text{current}; F = \text{force}$

**Figure 5.84** Orientation of Lorentz Force [Fair Use]

*Orientation of Lorentz force with respect to the direction of the positive current as well as of the magnetic field.*

*Right-hand rule for a current-carrying wire in a magnetic field  $B$ .*



See figures 5.85 and 5.86 below. The black arrows depict the intersection of the current and magnetic field lines oriented at right angles relative to one another. The white arrows represent the resultant Lorentz forces derived from those interactions.

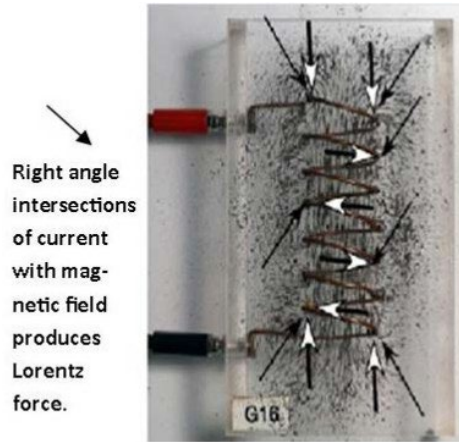

[tsphysics.mit.edu/front/](http://tsphysics.mit.edu/front/)

**Figure 5.85** Solenoid with Magnetic Filings and Direction of Lorentz Force [Fair Use]

- The black arrows depict the locations of the interaction of the current with its own induced magnetic field, moreover, at right angles relative to each other. The white arrowheads represent the direction of the resultant Lorentz forces from those interactions.
- Note with reference to the overall solenoid, there is no  $\rightarrow_{net}\leftarrow$  Lorentz force, because all the forces counteract one another or are blocked by the solenoid's physical structure. In essence, there are Lorentz forces present, but there is no  $\rightarrow_{net}\leftarrow$  Lorentz force.

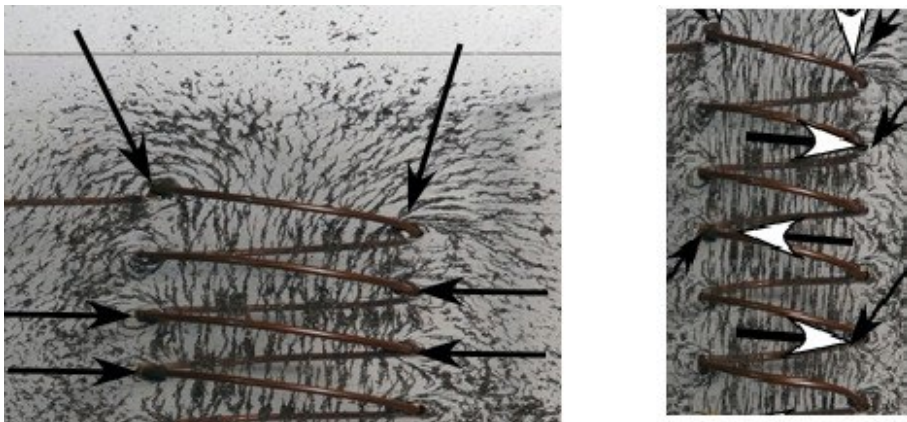

[tsphysics.mit.edu/front/](http://tsphysics.mit.edu/front/)

**Figure 5.86** Right-angle Interactions [Fair Use]

The image above is a distorted and magnified image, so the reader can easily visualize the right-angle interactions of the current with the magnetic field lines.

Observe that all the Lorentz forces either counteract one another or else are blocked by the solenoid's own intact physical structure. So, just as was demonstrated in the straight wire conductor example, even though there are Lorentz forces present, there is no net Lorentz force, thus no motion, propulsion, or work.

Below, in summary, are three separate groups of figures, 5.87, 5.88, and 5.89, portraying the analogous functions of an EM versus a PM. The following captions are self-explanatory.

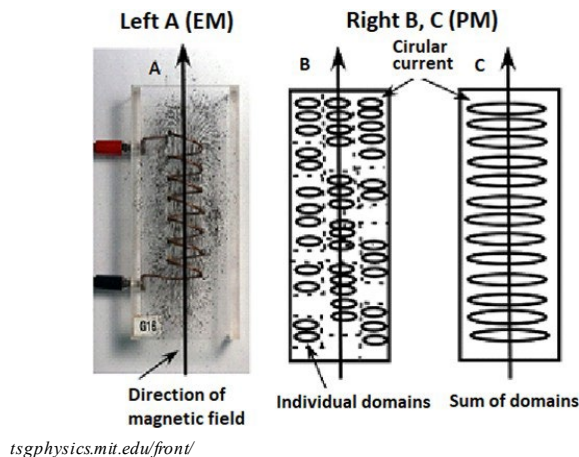

**Figure 5.87** Electromagnet A, Permanent Magnet B and C [Fair Use]

- *A is an electromagnet; B and C depict a PM. The directions of the multiple circular currents are oriented as if directed from "out of the page" on the left side and "into the page" on the right side. The multiple circular currents then produce an overall internal magnetic field, which is directed towards the top of the page, represented by the upward-oriented large vertical straight arrow.*
- *(C) is the summation of all the individual domains of B. This illustration also shows that the function of an electromagnet and a permanent magnet are identical.*

The following figures 5.88 and 5.89 establish that the external, as well as the internal, magnetic fields of both an EM and a PM are identical.

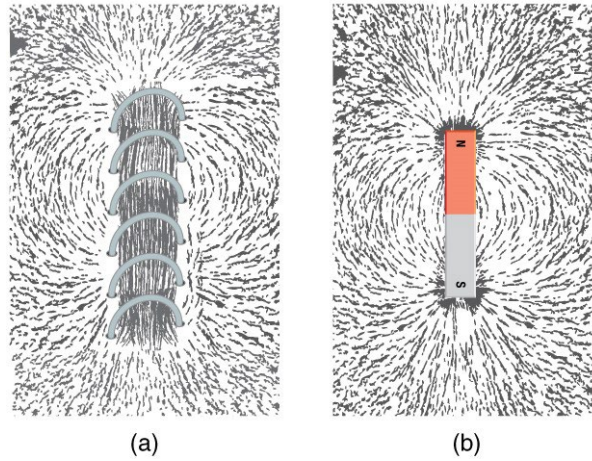

Wikipedia

**Figure 5.88** External Magnetic Fields [Fair Use]

*External magnetic fields are identical for both a PM and EM (figures 5.88 and 5.89).*

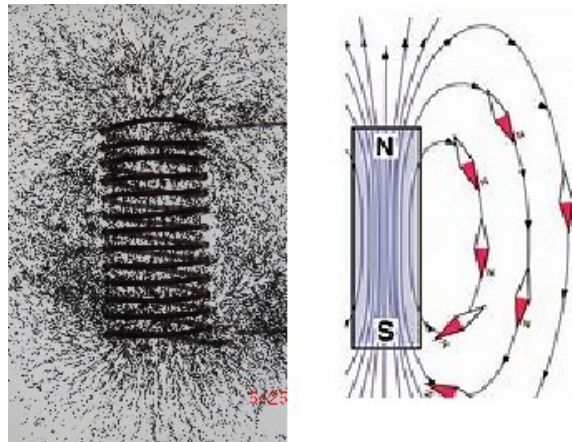

University of Michigan

Hyperphysics

**Figure 5.89** Internal Magnetic Fields [Fair Use]

*Internal magnetic fields are identical for both a PM and EM (figures 5.88 and 5.89).*

**(b) Internal Lorentz Forces of Single PM**

Up to this point, the main thrust of discussion has generally revolved around the EM. However, now the same physics will be extrapolated, moreover, shifted, so that the focus is now on a PM. This is because it already has been established that the physics of a PM and a solenoid (EM) are identical. The following illustrations present the extrapolation, as well as the correlation. Refer to Figure 5.90 below, and the following dissertation.

As depicted in Figure 5.90, a solitary PM (right), which is analogous to a solenoid EM (left), generates its own magnetic field lines. Subsequently, those lines interact with the circular domain currents located within the PM's own internal structure.

This interaction then generates Lorentz forces. Notice that they consist of opposing symmetrical forces, which counteract one another, or else forces that are blocked by the PM's own internal structure. Therefore, with respect to a solitary PM, indeed, Lorentz forces are produced, but there is no net Lorentz force. As such, there is no movement, work, or propulsion.

In other words, with regard to a standalone PM, relentless Lorentz forces are always generated/present, moreover, devoid of the classical input of energy; even so, there is no movement, thus no work ( $W = F \times \text{distance}$ ).

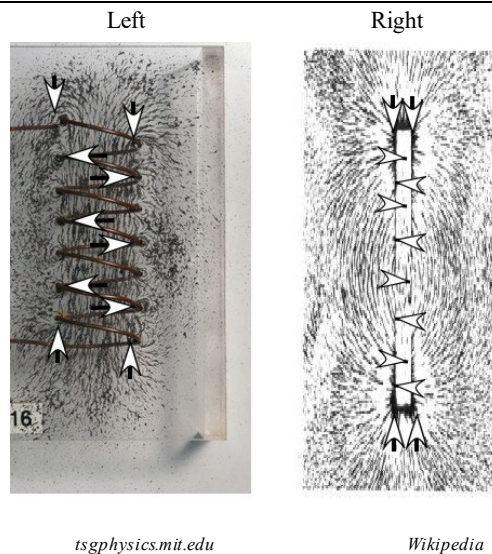

**Figure 5.90** Electromagnet Left and Permanent Magnet Right [Fair Use]

- The white arrows portray the internal Lorentz forces at different locations within both kinds of magnets. They are a product of the interaction of the currents with their own generated magnetic field lines.

- For both types of magnets, there is either opposing symmetry (vertical arrows) or alternatively, the Lorentz forces are blocked by the magnet's own internal physical structure (horizontal arrows). Therefore, with respect to a solitary EM/PM, even though Lorentz forces are present, there is no net propulsion or movement.

- Figure 5.90 to the right **partially** explains the reason why, when a PM is split physically longitudinally, along its own magnetic field axis, there is repulsion of the two halves away from one another.

---

For the benefit of the nonphysicist, this concept will be re-explained from a slightly different angle. Pertaining to a solitary PM, as a function of perpetual superconducting circular electron domain currents, which then interact with their own induced magnetic field, Lorentz forces are constantly being generated, moreover, without an apparent input of energy. Nevertheless, given that these forces either are oriented anti-symmetrical or else are blocked by the PM's own physical structure, therefore balanced, there is then no movement or work ( $W = f \times d$ ). In addition, these forces are assumed by most individuals, incorrectly, not to exist.

And so, the objective of these two novel types of motors is to capture these persistently generated Lorentz forces to do practical work, again without the input of classically defined energy.

As it will be clarified later on in this chapter, these types of motors cannot be explained by using the classical assumption, whereby the force generated by two interacting PM's is located in the region of the interacting fields outside the PM's own physical structure.

And second, it is inexplicable, presuming that there are no permanent intrinsic Lorentz forces constantly being generated by a standalone non-interacting PM devoid of energy input.

Alternately, the function of these new forms of motors can be understood, if one posits that a single non-interacting PM continually generates Lorentz forces. However, because they are either oriented anti-symmetrically or blocked forces, there is no movement or work. Fundamentally, these forces are always present but not apparent.

So, when given the proper configuration involving multiple PMs, these hidden forces can then be captured to produce useful work. This is the essence of the underlying physics of these types of motors.

**5. Interacting PMs**

Now, how about interacting PMs? Please refer to Figure 5.91 below and the following discussion. →See repulsion in Figure 5.91, left←. Presuppose there are two opposing PMs in the orientations as revealed. When compared to the magnetic field of a solitary non-interacting PM, the new unified field that forms, changes configuration. Essentially, relative to the physical flat ends of the inner north poles, the magnetic field lines then turn out to be oriented more horizontally/parallel. For that reason, compared to a single PM, the previous opposing, moreover, counteracting symmetry is then altered.

In this new setting, the interaction of the now more horizontal/parallel-oriented magnetic field lines, with their own domain currents of the two central north poles then changes alignment. For that reason, at these locations, there is an increase in the vertical-oriented Lorentz forces. This is not the case at the position of two south poles, because in those regions, there is no alteration of the field lines.

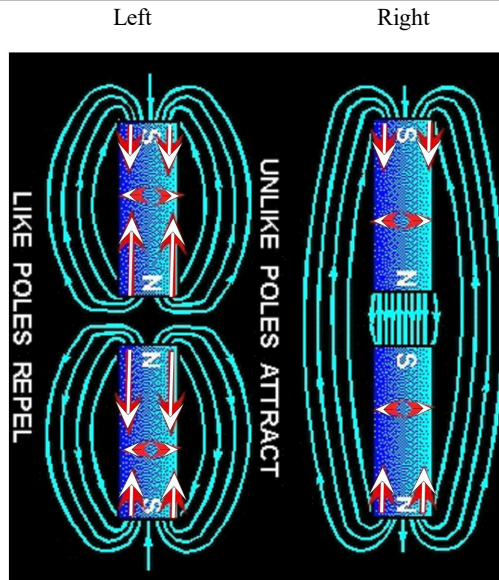

<http://www.uq.edu.au/SchoolScience/Lessons/29.1.1.4.GIF>

**Figure 5.91** Drawing of Magnetic Fields for S/S and S/N Magnets [Fair Use]

*The illustration above is not quite representative. In reality, regarding the repulsion schematic, rather than two separate fields, there should be only a single unified magnetic field. Regardless, the illustration is useful for comprehending the concept.*

As demonstrated in Figure 5.91 (left) the vertical Lorentz forces located within the two central north poles are now greater compared to the opposite-oriented vertical Lorentz forces located within two outer

south poles. Therefore, the two PMs repel away from one another. Take notice: the small horizontal arrows (Lorentz forces) located inside each magnet are symmetrical and counteract one another.

→See attraction Figure 5.91 right←. Pertaining to the setting where there are two attracting PMs, moreover, when compared to the magnetic field of a solitary non-interacting PM, the new single unified field thus formed again changes configuration. Once more, the previously opposing, moreover, counter-acting symmetry with regard to a single PM is lost. So, vis-à-vis this second scenario, relative to the physical flat ends of the inner PMs, the magnetic field lines then turn out to be more vertically oriented. This effect then changes their interaction with their own domain currents located within the two inner poles. For that reason, at that location, there is then a decrease or absence of the vertical Lorentz forces. This is not so with regard to the outer poles for in those regions, there is no change in the orientation of the field lines.

Fundamentally, with reference to this second scenario, as demonstrated in Figure 5.91 (right), the vertical-oriented Lorentz forces located within the two central poles are then less than or absent compared to the opposite-oriented vertical Lorentz forces situated within two outer poles. Consequently, the PMs attract, or in reality, →propel towards one another←. Observe again, the small horizontal arrows (Lorentz forces) sited inside each magnet are symmetrical, moreover, negate one another.

Figure 5.92 below displays the same physics, but, rather than a schematic, these are actual images of the magnetic fields painted by iron filings. When viewing these photos, there are two important presuppositions to keep in mind. The first is that regarding the two interacting magnets, it is assumed that there is only one overall magnetic field, complex yes, but still only one field. The second is to observe the change in configuration of the magnetic field lines located between the two central interacting poles, as a function of attraction versus repulsion.

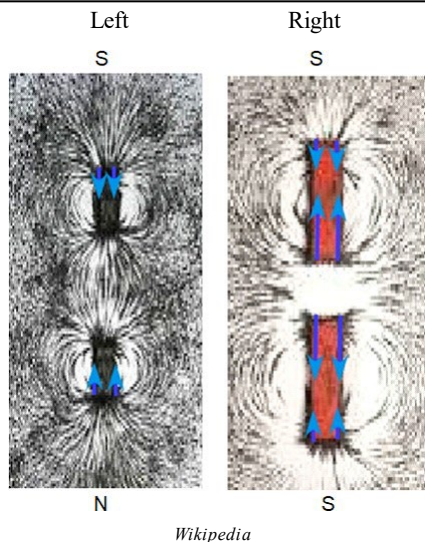

**Figure 5.92** Magnetic Filings for S/N and S/S Magnets [Fair Use]

*For each interaction, presume there is only one overall complex magnetic field. Now, with regard to repulsion versus attraction, observe the change in configuration of the magnetic field lines, vis-à-vis the two central interacting poles. In addition, note that the outer poles' magnetic field lines remain relatively unchanged.*

Refer to Figure 5.92, right side (repulsion). When the two central north poles repel one another, regarding their two inner physical flat ends, then the induced magnetic field lines tend to become oriented more parallel or horizontal relative to those flat ends. This alteration produces an increase in the vertical repelling Lorentz forces. This transpires again because the more horizontal/parallel field lines then in-

crease their interaction with their own circular domain currents located within the two central north poles. In contrast, the two outer south poles' magnetic field lines remain unaffected, so, for those Lorentz forces, there is no change.

As a result, unlike the example of a single PM, whereby all of the Lorentz forces counteract one another or are blocked by the PM's own physical structure, therefore balanced, these two PM's possess unbalanced Lorentz forces. The vertically oriented Lorentz forces are now greater within the central north poles versus the opposite-oriented vertical Lorentz forces, which are located within the outer south poles. Therefore, the magnets repel one another until they are so far apart that they cease to interact. At that point, each of them functions as a single PM, again possessing balanced negating forces. Even so, relative to each other, they now possess momentum (velocity).

See Figure 5.92, left side (attraction). In contrast, when there are two central north and south poles, then relative to the two flat central ends, the magnetic field lines assume a more perpendicular or vertical orientation. This change in orientation produces, in that locality, a decrease in the vertical Lorentz forces. This occurs because the now more vertical field lines decrease their interaction with their own circular domain currents located within the two central inner poles. Again, the outer poles' field lines are unaffected; consequently, for those regions, the Lorentz forces remain unchanged.

As opposed to a solitary PM where all the Lorentz forces are balanced or blocked, these two PMs now possess unbalanced opposing vertical Lorentz forces, in this case, being greater within the outer poles as compared to within the inner poles. Therefore, in reality, the two magnets actually propel towards one another. Or as classically but incorrectly posited, they attract one another until they combine, thereby essentially transforming into one PM. This combined PM then functions as a single magnet, so at that time, associated with balanced as well as blocked forces.

With respect to a solitary PM, Lorentz forces are always being generated, furthermore, without apparent energy input. Forces are present, but there is no work/motion. In addition, whenever two PMs interact, moreover, move relative to one another, work is performed ( $W = f \times \text{distance}$ ), nonetheless, not practical work. So again, the goal of these new forms of motors is to capture these perpetual/permanent forces, devoid of classic energy input, in order to perform  $\rightarrow$ useful work $\leftarrow$  in the form of a motor. By using the alternative physics as just explained, new, novel motors are now presented as described below. There are two types of PM motors the author wishes to present.

- The permanent circular magnetic motor
- The shielded permanent magnetic motor

### 5.5.2 The Circular Permanent Magnetic Motor.

Assume a circle is assembled from attached, adjacent, rectangular, permanent bar magnets (PM's), as shown below in figures 5.93 and 5.94. The PMs are the rectangles that make up the periphery of the circle. The attached magnets are positioned on the outer surface of the plane of a wooden wheel.

In addition, presuppose there is a pivot located at its wheel's center, which allows it to freely rotate clockwise or counterclockwise. The pivot also prevents motion in any other direction.

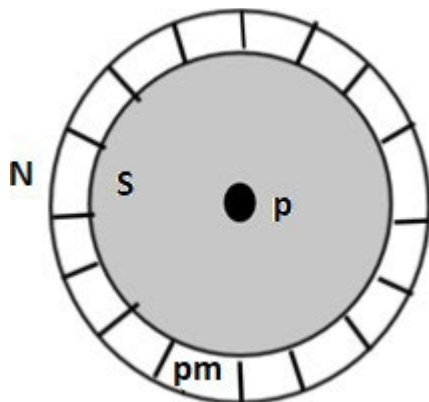

**Figure 5.93** Wheel with Attached Magnets

*The rectangles located peripherally on the outside of the wooden wheel represent attached PMs in the form of a circle.*

Presume the north pole axes of all peripheral PMs are oriented towards the outside of the wheel, as shown below in Figure 5.94. The numerous hollow-tipped arrows of this figure represent the looped magnetic field, but only relative to the plane of all the attached circle of magnets. Additionally, the magnetic field direction is from south to north inside the PMs and from north to south on the outside of the PMs.

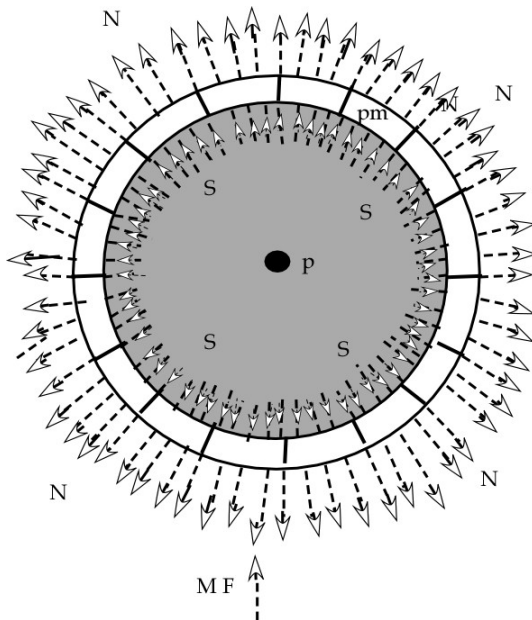

**Figure 5.94** Looped Magnetic Fields

- *The rectangles located peripherally on the outside of the wooden wheel represent attached PMs in the form of a circle.*



- Dotted arrow = magnetic field.
- In reality, this is a looped magnetic field, but with respect to this illustration, only the plane of that magnetic field is shown.
  - The central black dot depicts the central axis/pivot of the wooden wheel.
  - The density of arrows corresponds to the strength of the magnetic flux, not their lengths.

### Function

The circular currents located within the domains of the PMs generate the magnetic field. The magnetic field then interacts with those currents to produce Lorentz forces which are oriented as depicted below in Figure 5.95. Discern, the internal Lorentz forces that are attempting to split each individual PM are not shown.

Observe, as in Figure 5.95, the Lorentz forces counteract one another or are blocked by the PM's own internal composition, as well as from the overall intact physical structure of the circle of PMs. They are only balanced forces. As a result, even though Lorentz forces are persistently present, there is no net Lorentz force; therefore, there is no movement, work, or rotation.

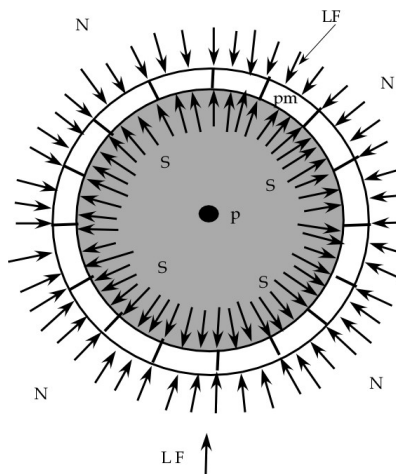
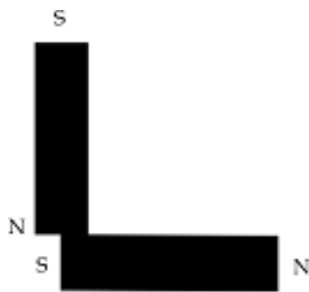

**Figure 5.95** Opposing Forces Blocked by Physical Composition

- Solid arrow = Lorentz force.
- The Lorentz forces inside the circle are greater than outside the circle, but symmetry and the intact structure of the circle prevents motion.
  - The internal Lorentz forces attempting to split each individual PM are not shown in the illustration. This effect was explained earlier in this section.
  - Fundamentally, the Lorentz forces counteract one another or are blocked by the internal physical structure of the PMs, as well as from the overall intact physical structure of the ring of PMs.
  - Essentially, they are balanced forces, therefore, no movement or work.
  - The density of arrows corresponds to the strength of the Lorentz forces not their lengths.

Next, assume on both sides of the wheel, 180 degrees apart, that two bar-shaped PMs in an L configuration are compressed against the wheel as shown below in figures 5.96 and 5.97.

Observe how this function of compression by the two L-shaped PMs alters the configuration of the magnetic field of the assembled circle of peripheral PMs. In other words, as a result of the compression, there is an alternation in the configuration of the wheel's magnetic field.



**Figure 5.96** L-shaped PMs

*Two PMs are assembled in the form of an L.*

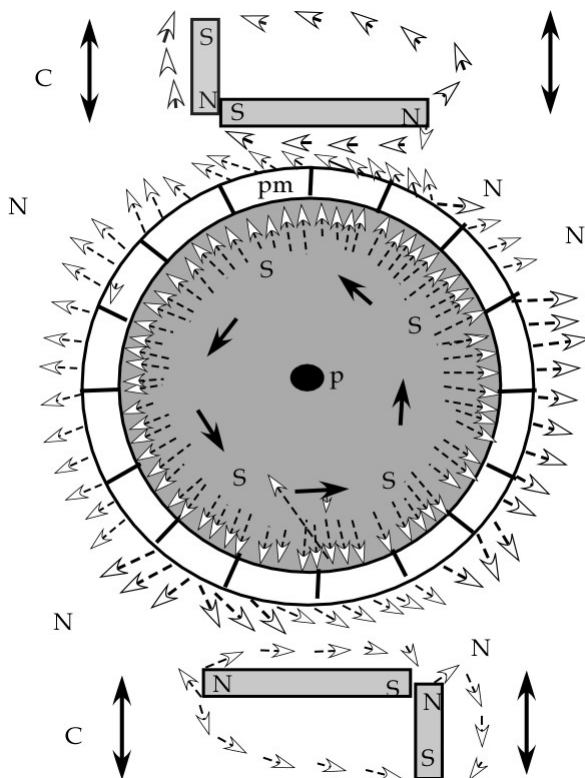

**Figure 5.97** Magnetic Field of the Two L-shaped Magnets Compresses the Magnetic Field of the Wheel

*As a function of compression by the two L-shaped PMs, the magnetic field of the wheel of attached PMs then changes its configuration as portrayed above.*

As a result, as illustrated below in Figure 5.98 below, there is also a change in the direction of the wheel's resultant Lorentz forces (torques). Therefore, they are now not symmetrical or blocked forces; they are asymmetrical or unbalanced forces.

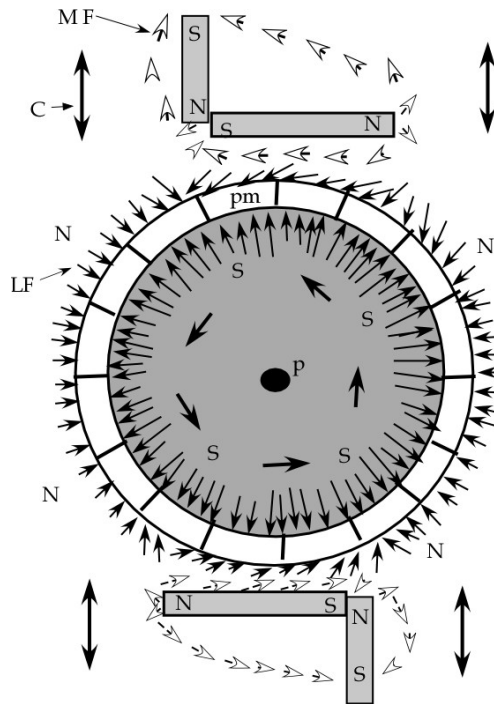

**Figure 5.98** The Sum of the Lorentz Forces

*The sum total of the vector Lorentz forces (torques) driving the wheel counterclockwise is greater than the sum total clockwise. Consequently, the wheel continues to rotate counterclockwise for the duration of the function of compression.*

There are vector forces directed against the wheel's pivot from both sides, but the wheel is fixed at the pivot; therefore, those forces are counteracted/neutralized.

However, the sum total vector Lorentz forces derived from all the PMs (torques) driving the wheel counterclockwise is now greater than the sum total clockwise. So, for the duration of compression, the wheel continues to rotate counterclockwise, moreover, after the initial compression without apparent input of energy. Now, as a function of continuous compression, so long as the overall magnetic field is persistent in this form, then the wheel will continue to rotate devoid energy input. Essentially, since the unbalanced forces are persistent, so too is the rotation persistent, moreover, without energy input. Remember that a PM can last 20 years.

But, as usual, all is not that simple. Recall that a torque is a coupled force. This form of motor is geometry-dependent, as well as strength-of-gauss dependent. So in all cases, this novel motor works using two L-shaped magnets each of which is located on opposite sides of the wheel, furthermore, driving the wheel in the same direction (diameter torque). This is because by using the diameter torque, from two L-shaped PMs, there are always more Lorentz forces driving the wheel counterclockwise than clockwise. So the wheel then persistently rotates with continued static compression.

However, in other specific configurations, by using only one L-shaped magnet on one side (radial torque), it does not work in all scenarios. This is because, given certain configurations, by using only one L-shaped magnet with radial torque, the total sum of the torques driving the wheel counter-clockwise versus clockwise can be equal. Therefore, regarding that specific geometric scenario, there is then no rotation.

The quandary is this: Where does the energy ultimately originate in order to power the motor? By quick oversight, all of the above violates the law of conservation of energy. Nevertheless, assuming there is energy located in the vacuum of space (ether) as theorized, or perhaps, even proven by modern physics, then the author posits that this is the source of that energy. This vacuum energy maintains the circular domain's currents without obvious energy input.

If the reader does not believe that a PM can create energy without losing energy, then ponder this logic. Picture in your mind a solitary PM. Next, imagine attaching it to a large metal bolt; leave it there for a week and then separate them. During that time, the PM has not lost energy. In fact, a PM lasts longer if left attached to the bolt. However, the bolt is now magnetized.

Bear in mind, it required energy to rearrange the bolt's electrons in order to effect magnetization. In other words, the PM has not lost any energy. Even so, energy was utilized to rearrange the bolt's electrons to induce magnetism. So again, where does this energy originate? It comes from the energy of the vacuum of space, essentially another name for **the ether**.

### 5.5.3 The Shielded Permanent Magnetic Motor

By using the five basic attributes previously elucidated in the first part of this section, a limited explanation describes how to build an over unity-shielded PM motor.

But first, for review:

- Presupposing the classic laws of modern physics are correct, it is posited that a standalone PM produces no intrinsic forces/energy. In addition, the classic theory posits that when the magnetic fields of two PMs interact, outside their physical structures, it is at this locality where force occurs. However, in fact, persistent force occurs within the PM's own physical structure where the generated magnetic field interacts with its own current, without apparent energy input.

- Recall work = force x distance. However, this is not the same concept as force alone. So, when two PM's interact, forces are generated. Nevertheless, only if they are allowed to move relative to one another, then and only then, in that setting, work occurs. Otherwise, there exists only persistent force.

- Now, regarding two interacting PMs, moreover, as a function of repulsion or attraction, any motion induced is indeed work, although not practical work (e.g., motor). For instance, a hypothetical functioning motor assembled from two PMs, one acting as the rotor and the other fixed outside, has never been successfully built (see Figure 5.99 below). This is because the counteracting repulsion functions prevent the rotor magnet from completing a single circuit of over 360 degrees. Therefore, there is work but not practical work. Again, an example of this concept is shown below in Figure 5.99.

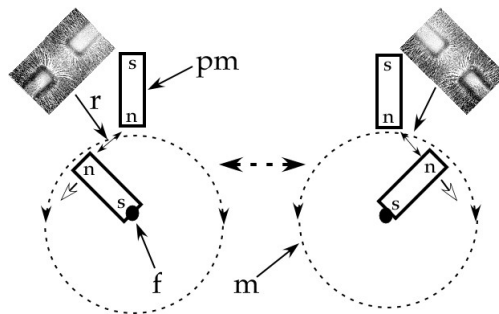

**Figure 5.99** Practical Work is Not Possible; Magnetic Images Show Repulsion

*Due to symmetrical mirror image repulsions, the rotor magnet (inside the circle) cannot complete a 360-degree circuit. Therefore, a true motor is not possible. Take note, there is motion (work), however, not practical motion.*

- In addition, with reference to classic modern-day physics theory, aside from the repulsion or attraction of two PMs, it is posited that there is no practical intrinsic energy/force to capture in order to create such a device. Principally, this is the law of the conservation of energy.

- Alternately, presupposing that the alternate principles of physics, as portrayed earlier in this section, are valid, then a solitary PM is, in fact, associated with intrinsically perpetually generated Lorentz forces devoid of recognizable energy input.

Nevertheless, as a function of Lorentz force, anti-symmetry and the PM's own intact physical structure, no practical or useful motion or work transpires. Now, if the reader does not agree with this hypothesis, please pay close attention to the following three observations.

1. Whenever a solitary rectangular bar PM is split longitudinally, along its magnetic axis, the two halves then repel from one another. So, given this fact, consider this logic. Within the bar PM, there must be intrinsic longitudinal splitting persistent forces constantly being generated, nevertheless, blocked by its own intact internal structure. They are not perceived, until, as above, the PM is split longitudinally. This concept is more intricate since wherever the bar PM splits longitudinally, transforming into two separate magnets. Then immediately, the field lines rearrange, so that there is then classic repulsion relevant to two separate adjacent (side-by-side) bar PMs oriented with the same polarity. So, assuming that the author's hypothesis is factual, the initial, but not secondary, splitting function is real but not apparent.

2. In addition, if one holds two attracting PMs steadfast, even for years, thus preventing motion, a relentless force is continuously present, even without obvious input of energy.

3. As previously stated, if a PM is attached to a piece of steel/iron for a week and then separated, it magnetizes that object. Discern that the PM is unaffected; even so, it requires energy to produce the magnetization effect. This is an over unity concept.

And so, the goal of this motor is to utilize a novel magnetic shield, among other physical attributes, to capture the persistent intrinsically generated Lorentz forces of two repulsing PMs in order to produce useful work absent apparent energy input. The function of this device is a violation of the law of conservation of energy.

The alternative physics previously explained in the beginning of this section was very time-consuming, furthermore, complex, but necessary in order to appreciate how this over unity PM-shielded motor actually works, which is as follows.

In order to construct a motor of this kind, it is necessary to build a magnetic shield that neither attracts nor repels a solitary externally placed PM. In contrast, it must be capable of reducing/diverting a magnetic field, such that it decreases the Lorentz forces of two repelling PMs when placed on opposite sides of the plane of the shield.

This form of shield is constructed by utilizing numerous other small PMs as presented below. See figures 5.100, 5.101, and 5.102.

So now, here is the methodology of how to construct a shield of this type.

1. On one side of a 3mm-thick, 4-inch by 4-inch aluminum flat metal plate, 2mm x 1mm x 5mm permanent neodymium magnets with opposing poles relative to their widths are positioned side by side, as portrayed below. They attract each other in this position, so it is relatively easy to produce a single sheet. An entire square, 4-inch by 4-inch, is then assembled, as shown below.

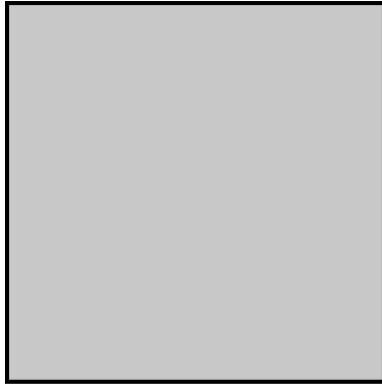

**Figure 5.100** Flat Aluminum Plate

*Figure 5.100 depicts a .5 cm-thick square plate (4" x 4") made of aluminum.*

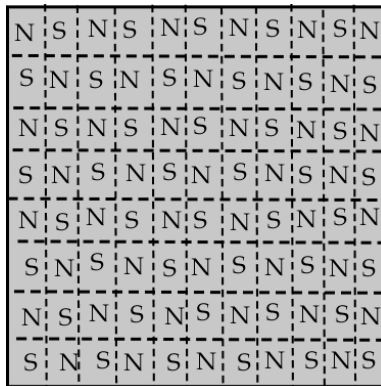

**Figure 5.101** Front view

*On one side of the plate, 2mm x 1mm x 5mm permanent neodymium magnets with opposing poles, relative to their widths, are arranged side by side.*

2. Next, relative to the plane of the metal plate, successive symmetrical layers of similarly aligned PMs are laid down until the desired thickness is achieved, in this case, five layers.

Figure 5.102 is a photo of the actual shield, but in this case, on both sides of a single aluminum plate.



**Figure 5.102** Photograph of Actual Shield

Given the fact that this type of shield is constructed from an equal number of opposite-oriented magnetic poles, there is no overall effect exerted on a single externally placed PM. This is a non-attracting/non-repulsion magnetic shield. For future reference, this form of shield will be labeled as (NANRMS). Additionally, with respect to this section, unless otherwise specified, the term shield and NANRMS are assumed to be synonymous.

The above effect only occurs if the external PM is at least a half-inch away from the shield. When closer, there is a slight attraction. Furthermore, when extremely close, it totally reverses the direction of some domain currents located within the shield's many PMs. As a result, it attaches itself to the shield.

This type of shield (NANRMS) functions several ways. First, even though it does not attract or repulse a solitary externally placed PM, it does result in reduction of repulsion between two PMs of the same polarity when on either side of the shield. One can test this effect by observing the amount of repulsion, with the shield present, and then without the shield.

Recall, outside a PM, the magnetic field travels from south to north, and within its substance, north to south. Furthermore, recollect that an electric field's strength decreases, as a function of the inverse square of the distance, theoretically to infinity. In contrast, this is not the case with respect to the magnetic field of a PM. Essentially, a magnetic field curves back upon itself, outside its own physical structure from south to north and travels inside from north to south. So, the field generally decreases as a function of inverse third power (or more) of the distance, although this also depends upon its physical shape.

So just how does the NANRMS actually work? As a possibility and only an option, the shield could, regarding a single external PM sited relative to one of its sides, divert a portion of its circular magnetic field back upon itself before it travels through the shield.

→This diversion occurs because the shield spreads out a portion of the external penetrating magnetic field, within its own internal substance, whereby it then returns to the external PM opposite pole, thus reducing its overall penetration through the shield←.

In addition, relative to the shield's other side, this spreading-out function also spreads out the remaining field lines as they exit the shield. So, assuming there is an opposing PM placed on the other side of the shield, with a more localized or concentrated field, then compared to if there was no shield, there is then less interaction between the two opposing PMs. Furthermore, in the scenario where there are two opposing polarities, sited on opposite sides of the shield, then as just described, moreover, with respect to

both sides, exactly the same processes occurs. In effect, the shield symmetrically (functionality) reduces the forces of repulsion of those two PMs when positioned on opposite side of the NANRMS (e.g., two repulsing north poles).

Third, regarding a solitary external PM placed on one side of the NANRMS and with respect to its other side (NANRMS), the shield alters the direction of the remaining penetrating field lines as they exit the shield on that side. Essentially, on the other side, as the remaining field lines exit, relative to the plane of the shield, their orientations tend towards perpendicular, as well as increasingly angled inwards towards the axis of the originator PM.

Again, for the benefit of novice, →regarding two repulsing poles located on either side of the NANRMS←, what really transpires with respect to this form of shield is this.

- The NANRMS returns a portion of the magnetic field generated by each external PM back upon itself, moreover, within the shield; thus, for that fraction, it completes the circuit without traversing through the shield. This symmetrical effect occurs with respect to both sides. This function reduces the repulsion of two opposing PMs when placed on opposite sides of the NANRMS.

- In addition, as for those remaining magnetic field lines which successfully travel through and exit the NANRMS, they become more spread out. So, for any interface with a more concentrated magnetic area located on the other side, there is then less interaction. This function also results in a reduction in force of the two repelling magnets. Again, this symmetrical effect occurs with respect to both sides.

- The NANRMS also changes the direction of the remaining field lines, as they successfully travel through and exit the shield. Therefore, relative to both sides, this alteration changes the interaction with the opposing magnetic field lines with their own domain currents.

- Furthermore, there is another factor to consider. This is related to the orientation of the Lorentz forces that are directed at the rotor's pivot. This subject will be clarified later in this chapter.

The author has actually built a shield of this type, so it does work as advertised. This is the result of years of experimenting with PMs. However, this hypothesized motor is very complex, moreover, with so many different interacting magnetic fields and functions, the author does not really comprehend how it would actually work. The author posits the basic theory but does not fully comprehend the details.

Therefore, to simplify some core functions, the following principles are presented, even though these descriptions do not characterize the overall physics applicable for the construction of such a device. In reality, the hypothesized motor is much more complicated, since there are multiple types of shields, moreover, the inner rotor/armature magnet is not a single linear-bar PM, rather extremely complex.

In summary, the following principles explain only some of the physics involved. Even so, they are not adequate enough to successfully build a motor of this type. In other words, the author cannot completely explain its intricate functions. For that reason, it ultimately may be necessary to build a number of them, give them away, and then let others clarify the physics involved. In order to simplify the motor's inner workings, first six basic principles are presented with illustrations followed by descriptions and explanations. Subsequently, these principles will be used to give explanation to some, although not all, of this motor's functions.

### Principle 1.

See Figure 5.103. Principle 1 is a review of previous deliberations. Observe the shape of the central interacting magnetic field lines of (A) compared to (B). In this case, relative to the two central flat physical poles, the field lines become more transverse, parallel, or horizontal. Therefore, there is repulsion. In addition, note the shape of the central magnetic field lines of (C) compared to (B). In this second setting, relative to the two central flat poles, the magnetic field lines then become more perpendicular or vertical. Consequently, there is attraction.

(Repulsion) With reference to the two central north poles, the alterations of the magnetic field lines produce a change in the magnitude of the vertical Lorentz forces. This is because when A is compared to B, the rearranged magnetic field lines then change their interaction with their own domain currents within the two central north poles. Essentially, the field lines become more horizontally parallel relative to the physical flat ends of the two central poles. As a result, there is an increase in the vertical Lorentz forces, as compared to the opposite-oriented vertical Lorentz located within the two outer south poles whereby there is no change. Therefore, the two PMs repel away from one another.



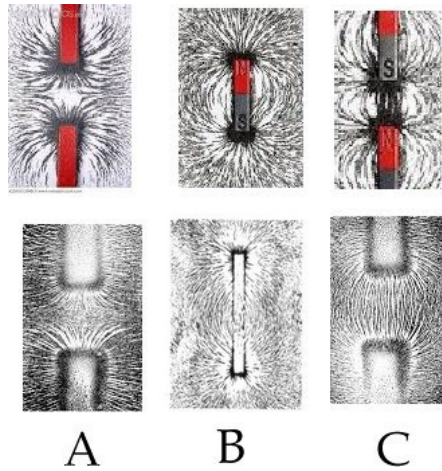

Wikipedia

**Figure 5.103** Comparing Magnetic Fields [Fair Use]

*Figure 5.103 depicts the magnetic field of:*

- *A = repulsion forces of two PMs*
- *B = balanced forces of one PM*
- *C = attraction forces of two PMs*

(Attraction) Now, regarding (C) versus (B), the magnetic field lines become oriented more towards perpendicular relative to the physical flat ends of the two central poles. Consequently, within the domain currents of the central poles (N, S), there is then a decrease in the vertical Lorentz forces compared to the opposite-oriented vertical Lorentz forces sited within the two outer poles (S, N) whereby there is no change. As such, in reality, the two PMs propel towards one another. Nevertheless, we perceive this function en erratum as the two PMs attracting one another. In reality, it is a propulsion force not an attraction force. Once again, bear in mind, relative to both repulsion and attraction (Figure 5.103), the internal horizontal Lorentz forces attempting to split each separate magnet apart longitudinally (not shown) are symmetrical and counteract one another.

**Principle 2.**

Figure 5.104 represents the motor's physical structure but devoid of a shield. As such, without a shield, it is nonfunctioning. Even so, it does depict the motor's basic structure.

In reviewing Figure 5.104 below, you'll see that the inner bar (PM) is the rotor, which is attached at a fulcrum/pivot. Its north pole polarity is as shown. The outer fixed PM, including its north pole polarity, is also pictured.

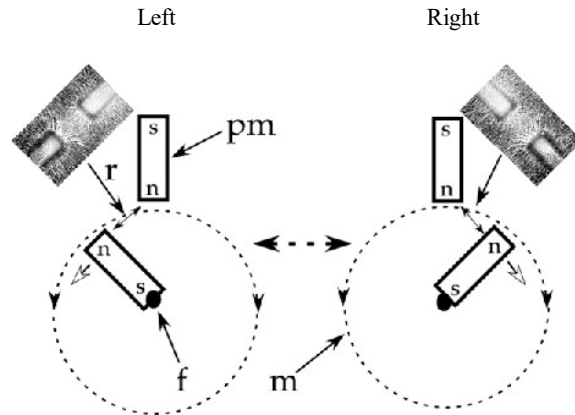

**Figure 5.104** Motor with No Shield; Magnetic Images Show Repulsion

- *pm = permanent magnet*
- *f = fulcrum*
- *Photos are of repulsion*
- *m (dotted circle) = motor*
- *n, s = north and south poles*
- *r = repulsion*

Therefore, as illustrated, if one positions the rotor's north pole in either of the two-mirror image positions, then with respect to these orientations, the opposing north poles symmetrically repel one another. Consequently, on the right, the repulsion produces clockwise rotation. Alternatively, on the left, there is counterclockwise rotation.

So as depicted in Figure 5.104, because of the counteracting repulsions, the rotor magnet cannot complete a full 360-degree circuit. For that reason, a functioning motor cannot be built.

**Principle 3.**

Now, presume a flat plate-like magnetic shield consisting of iron/steel (sms) is positioned halfway between the longitudinal axes of the outer fixed PM as shown below in Figure 5.105. Note, this is not a NANRMS. It only functions as a classic magnetic shield. Therefore, it attracts both opposing north poles. For that reason, a motor is not possible, since again the rotor PM cannot complete a full 360-degree circuit.

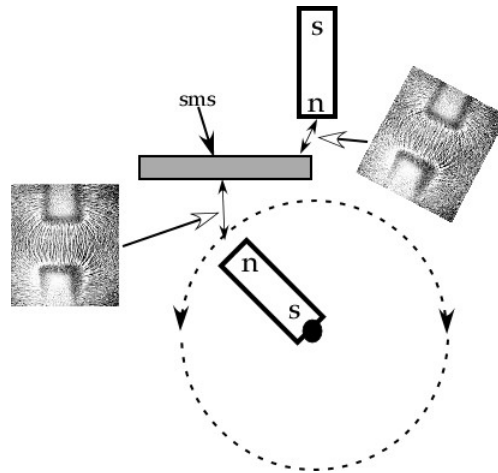

**Figure 5.105** Motor with Shield; Magnetic Images Show Attraction

- *sms = classic steel or iron magnetic shield.*
- *Figure 5.105 portrays a classic shield made of iron/steel (sms). This kind of shield attracts both opposing north poles. As a result, the rotor magnet cannot continuously rotate in one direction.*

**Principle 4.**

Please refer to Figure 5.106 below, furthermore, the pre and post discussions. Figure 5.106 portrays two separate scenarios. The first, or upper schematic, demonstrates the configuration of the magnetic field of two repelling north poles, absent a shield.

The second, or lower schematic, depicts the same PMs, moreover, in the same orientations. However, in this setting, both opposing PMs are in the presence of this intervening new form of shield (NANRMS). Observe, regarding the two central interacting north poles, just how this shield changes the magnitude, as well as orientations of the remaining field lines as they traverse and exit the shield on each side. Essentially, they are reduced, moreover, with a change in direction.

Recall, the NANRMS functions as described without individually attracting or repelling either external PM. Basically, under the influence of the shield, the two opposing poles interact with reduced repulsion. Nevertheless, the shield, in and of itself, does not separately affect either external PM.

To recap, the NANRMS reduces the magnitude, moreover, rearranges the orientation of the remaining exiting field lines vis-à-vis two opposing externally placed PMs, with their north poles, sited on either side of the shield. This effect then alters the orientation and the strength of the repelling horizontal (specific to this schematic) Lorentz forces. In essence, relative to the two repelling central north poles, then under the influence of the NANRMS, there is a reduction of those repelling Lorentz forces.

See Figure 5.106. Again, as portrayed below, the NANRMS reduces, as well as diverts, the two opposing north magnetic field lines as they exit the shield on both sides. Therefore, this dual effect produces a change in orientation thus interaction of the magnetic field lines with their own domain currents located within both north poles. As such, there is then a reduction in the horizontal Lorentz forces, (specific to this schematic) as compared to the scenario without a shield.

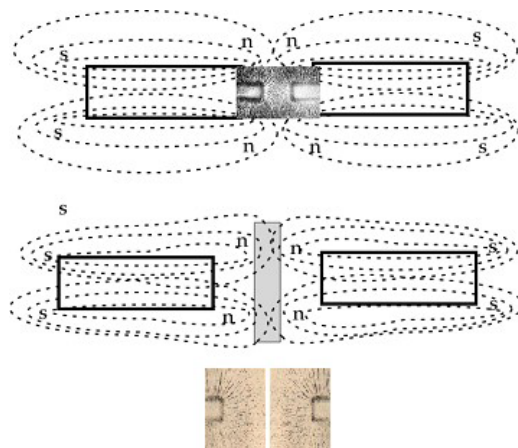

**Figure 5.106** Upper Magnet with No Shield; Lower Magnet with a Shield

The upper schematic shows the repulsion of two north poles without a shield. The lower schematic portrays the same PMs but now in the presence of an intervening non-attracting/non-repulsion magnetic shield (NANRMS). Observe, the NANRMS reduces the number of interacting north field lines, moreover, rearranges the orientation of the then remaining fields lines.

In other words, lower schematic compared to the upper schematic.

- The number of interacting field lines relative to both magnets are diminished.
- Relative the PMs physical flat ends, the remaining penetrating field lines become oriented more towards perpendicular.

This dual alteration has the effect of reducing the repulsion of, in this illustration, the horizontal Lorentz forces (the two repulsing north poles). So, in the upper schematic, there is repulsion, whereas in the lower one, there is reduced repulsion.

### Principle 5.

Refer to figures 5.107 and 5.108, in addition the pre and post deliberations. Figure 5.107 is a replication of Figure 5.104. Observe there is no shield. With reference to figures 5.104 and 5.107, recall the repulsion of the north poles clockwise is mirror image symmetrical to the repulsion counterclockwise. For that reason, the rotor magnet cannot complete a circle, so it cannot function as a motor.

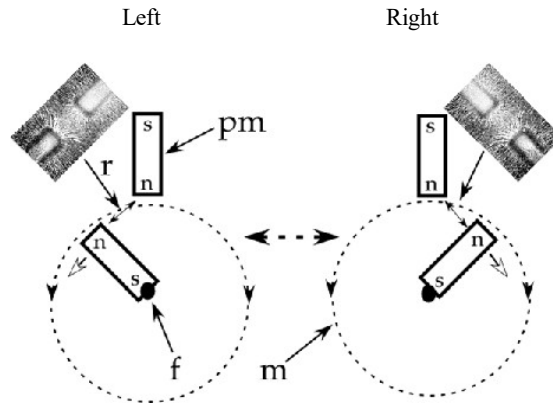

**Figure 5.107** Motor Without a Shield; Magnetic Images Show Repulsion

*Without a shield, the repulsion of the two north poles clockwise is a mirror image equal to the repulsion counterclockwise. Therefore, the rotor cannot complete a full circuit; thus, it cannot function as a motor.*

Alternately, concerning Figure 5.108 below, due to the presence of a NAMRMS while under its influence, there is a diminution of repulsion. So, regarding this scenario, the repulsion clockwise is greater compared to counterclockwise. If the difference is great enough, the rotor magnet then can complete a full circuit, moreover, repeat the sequence. This, in principle, is a motor.

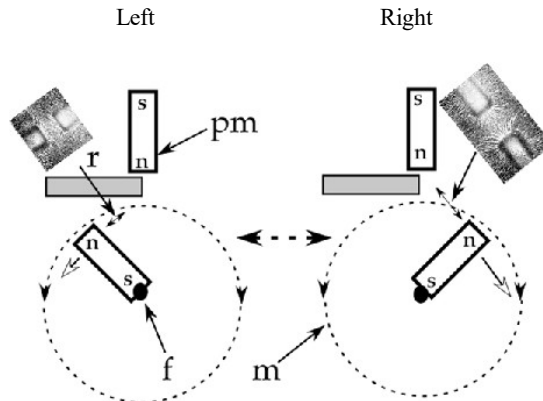

**Figure 5.108** Motor with Shield; Magnetic Images Show Repulsion

*Assuming the positioning of non-attracting/repulsion shield (NAMRMS) is as portrayed above, then the repulsion clockwise is greater compared to counterclockwise. The lengths of hollow arrows denote the magnitude of the amount of repulsion.*

*The clockwise arrow is longer in length than the counterclockwise arrow; therefore, if the difference is great enough, the inner rotor magnet can then complete the circuit, moreover, repeat the sequence, thereby functioning as a motor.*

**Principle 6.**

As previously indicated, there is another factor to consider, and it is this. Regarding the opposing PMs, not only does the novel NANRMS reduce the Lorentz forces between the two sides (opposing north external poles), but it also changes the direction of repulsion.

Under the influence of the NANRMS relative to the shield's flat surface, specifically located on the side towards the rotor, the Lorentz forces exerted on the rotor magnet are then oriented in line to its longitudinal axis.

This change in direction has the effect of repelling the rotor magnet directly against its own pivot. However, since the pivot is fixed, there is no movement.

To recap, as the rotor magnet approaches the outer fixed magnet, from the clockwise direction, then as a function of the NANRMS, not only is there reduced repulsion, but a larger portion of the remaining repulsion is now directed towards the rotor's own pivot. This is not the case once the rotor magnet passes the NANRMS, whereby full repulsion resumes, moreover, then not directed primarily against the pivot. This process is depicted as shown in Figure 5.109 below.

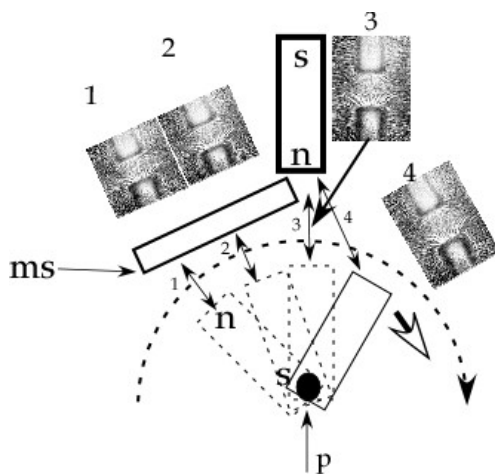

**Figure 5.109** Summary of Motor with Shield; Magnetic Images Show Repulsion

*The NANRMS also changes the direction of the Lorentz forces. Therefore, when the rotor magnet approaches the outer fixed magnet from the clockwise direction, the repulsion is then mainly directed along the rotor magnet's own longitudinal axis, thus directly against its pivot, which, in turn, prevents motion.*

*However, once the inner rotor magnet passes the outer fixed magnet/shield, the vector of repulsion is then oriented primarily in the clockwise direction.*

In summary, combining all six of the principles just presented, as well as prior explanations into one overall concept, here is the physical/functional description of this novel motor. Unlike iron or some forms of steel, the NANRMS does not generate an overall attraction/repulsion to other individual external PMs. This is because it is constructed from an equal number of very small PMs oriented so that, overall, the many fields negate one another.

In addition, as portrayed in all the above illustrations, during rotation when the rotor magnet approaches the external PM from the clockwise direction, there is an intervening NANRMS. As such, while under its influence, it undergoes a reduction in repulsive Lorentz forces. In addition, a larger segment of the remaining repulsion is directed against the rotor's own fulcrum/pivot, therefore, for that fraction, preventing motion.

However, the NANRMS ends halfway through the longitudinal axis of the outer PM. Consequently, at this juncture, the full repulsive forces resume. Furthermore, the repulsion is then not directed mainly to-

wards the fulcrum, rather, now clockwise in the direction of rotation. So overall, presuming the difference between clockwise vs. counterclockwise repulsion is great enough, this device is essentially a motor.

### Conclusion

PMs possess persistent Lorentz forces devoid of obvious energy input as imparted earlier in this chapter. Again, two repulsing PM's can perform work, nevertheless, not practice work. In contrast, regarding this motor, if repulsion is greater clockwise than counterclockwise as a function of the shield, then because of the motor's rotation, there are always a set of PMs in the position of being repulsed clockwise. So, in this case, repulsion is now practical in the form of a motor. Again, energy and work can be extracted due to the fact that PMs poses persistent Lorentz forces without apparent energy input. This is the source of the over unity.

Essentially, just like the circular PM magnetic motor described in the prior section, these same persistent Lorentz forces are now captured to perform useful work (a motor) vis-à-vis the shielded PM motor.

## 5.6 Gyroscopes as a Function of PFGRT

The framework of this subdivision is as follows:

- 5.6.1 Introduction
- 5.6.2 First Description
- 5.6.3 Second Description
- 5.6.4 Third Description
- 5.6.5 The Author's Description of the Function of a Gyroscope
- 5.6.6 The Authors of Two Experiments Relevant to Gyroscopes and Loss of Inertial Mass
- 5.6.7 Author's Postulate Regarding the Loss of Inertial Mass
- 5.6.8 Different Kinds of Experiments Versus the Loss of Inertial Mass
- 5.6.9 Precession Versus Forced Precession
- 5.6.10 Supporting Evidence for this New Theory/Postulate/Hypothesis
- 5.6.11 Another Hypothesis Regarding Gyroscopes and Inertial Mass
- 5.6.12 Gyroscopes as a Partial Function of Force
- 5.6.13 Further Discussion Regarding Inertial Mass
- 5.6.14 Propulsion Using Gyroscopes
- 5.6.15 Propulsion with Magnetic Fields

### 5.6.1 Introduction

*In 1974, Laithwaite was invited by the Royal Institution to give a talk on a subject of his own choosing. He decided to lecture about gyroscopes, a subject in which he had only recently become interested. His interest had been aroused by an amateur inventor named Alex Jones, who contacted Laithwaite about a reactionless propulsion drive he (Jones) had invented. After seeing a demonstration of Jones's small prototype (a small wagon with a swinging pendulum which advanced intermittently along a table top), Laithwaite became convinced that "he had seen something impossible." In his lecture before the Royal Institution, he claimed that gyroscopes weigh less when spinning and, to demonstrate this, he showed that he could lift a spinning gyroscope mounted on the end of a rod easily with one hand but could not do so when the gyroscope was not spinning as pictured below.*

*At this time, Laithwaite suggested that Newton's laws of motion could not account for the behavior of gyroscopes, and that they could be used as a means of reactionless propulsion.*

*The members of the Royal Institution rejected his ideas, and his lecture was not published. (This was the first and only time an invited lecture to the Royal Institution had not been published.) They were subsequently published independently as "Engineer Through the Looking-Glass." <http://www.peswiki.com> and Wikipedia*



Wikipedia



Imperial College, London

**Figure 5.110** Laithwaite with Gyroscope

If one watches the YouTube presentations by Eric Laithwaite, it is obvious that modern-day science lacks a complete understanding of how gyroscopes actually function. Without a doubt, these videos demonstrate that when a gyroscope precesses, it loses some of its inertial mass (weight). Moreover, when there is forced precession, there is then a lifting force. The apparent loss of inertial mass is pictured in the above photograph whereby Laithwaite lifts a heavy gyroscope while it precesses seemingly without effort. See Figure 5.110. See these YouTube sites:

<https://www.youtube.com/watch?v=MHLAJ7vySC8>

<https://www.youtube.com/watch?v=OpCEJxO6V9g> at 44 min. 40 sec.

<https://www.youtube.com/watch?v=NNLk5G3hgRg> at 4 min. 45 sec.

For further clarification, please refer to other YouTube videos as itemized below.

<https://www.youtube.com/watch?v=OpCEJxO6V9g>

<http://www.youtube.com/watch?v=MHLAJ7vySC8>

<http://www.youtube.com/watch?v=1eQp4grGdqY>

<http://projectavalon.net/forum4/showthread.php?>

Even so, Laithwaite's observations and findings have been totally ignored, moreover, rejected by the vast majority of modern-day physicists. What is more, he has been ridiculed, as in the time of Copernicus and Galileo. See this YouTube site:

<http://www.rense.com/general42/genius.htm>

There is a saying, "If one cannot learn from history, then one is condemned to repeat it." But the fact is the only thing we really learn from history is that we do not know the real history or learn from history; therefore, we repeat it (Voltaire). In essence, even in modern times, obvious scientific truths are often still repressed.

Later on in this section, several experiments are presented that confirm Laithwaite's hypothesis. But first, three classical descriptions of the fundamental physics of gyroscopes are presented. The first two were downloaded from the Internet, while the third is the author's own. Each is successively easier to comprehend. They are conveyed in this specific manner to demonstrate that even though modern-day physics can mathematically describe the function of a gyroscope, it is only when illustrated simply in three dimensions, that the average individual can then grasp the actual physical principles of a gyroscope. Then and only then, will one be able to comprehend by what means, while undergoing precession, a gyroscope loses inertial mass (weight).

Regarding the first two presentations, and especially for non-scientific individuals, most likely, they will not be able to make the connection vis-à-vis reduced inertial mass. In contrast, with the third de-



scription, the inter-relationship becomes clear to all. Additionally, only after comprehending the author's third description, will the following supporting experiments then make sense.

### 5.6.2 First Description

The following quotes and figures are all from the website Gyroscopic Effects: Vector Aspects of Angular Momentum:

<https://www.inkling.com/read/college-physics-openstax-college-1st/chapter-10/10-7-gyroscopic-effects-vector>

"Angular momentum is a vector and, therefore, has direction as well as magnitude. Torque affects both the direction and the magnitude of angular momentum. What is the direction of the angular momentum of a rotating object like the disk in figures 5.115 and 5.116?"

"The figure shows the right-hand rule used to find the direction of both angular momentum and angular velocity. Both  $L$  and  $\omega$  are vectors; each has direction and magnitude. Both can be represented by arrows. The right-hand rule defines both to be perpendicular to the plane of rotation in the direction shown. Because angular momentum is related to angular velocity by  $L = I\omega$ , the direction of  $L$  is the same as the direction of  $\omega$ . Notice in the figure that both point along the axis of rotation."

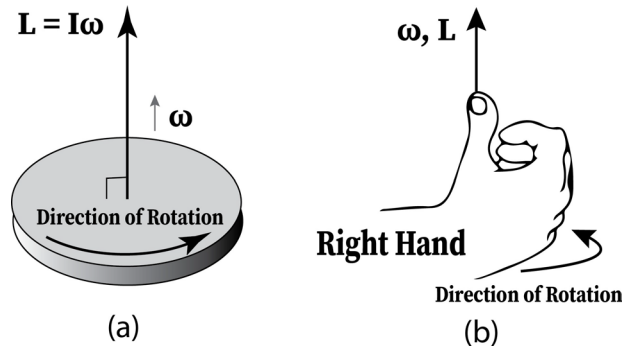

*Credit: David de Hilster*

**Figure 5.111** Direction of both Angular Momentum and Angular Velocity

Figure 5.111 (a) shows a disk that is rotating counterclockwise when viewed from above. Now, recall that torque changes angular momentum as expressed by:

$$\text{NCT } \tau = \frac{\Delta L}{\Delta t}$$

This equation means that the direction of  $\Delta L$  is the same as the direction of the torque  $\tau$  that creates it. This result is illustrated in Figure 5.111, which shows the direction of torque and the angular momentum it creates.

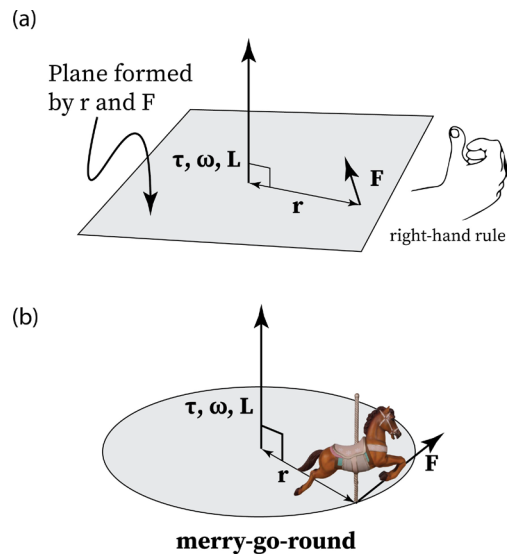

*Credit: David de Hilster*

**Figure 5.112** Torque is Perpendicular to the Plane Formed by  $r$  and  $F$

*In the figures above, the torque is perpendicular to the plane formed by  $r$  and  $F$  and is the direction to your right.*

---

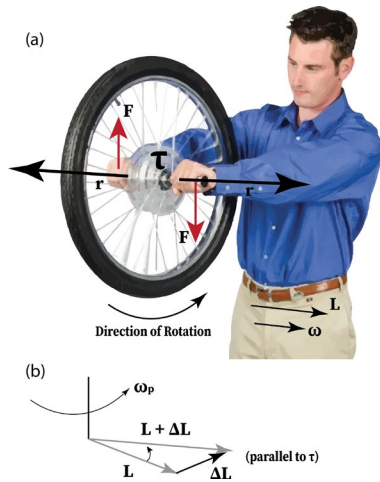

Credit: David de Hilster

**Figure 5.113** Changing the Direction of  $L$

Let us now consider a bicycle wheel with a couple of handles attached to it, as shown in Figure 5.113 above.

“This torque creates a change in angular momentum  $L$  in the same direction, perpendicular to the original angular momentum  $L$ , thus changing the direction of  $L$  but not the magnitude of  $L$ . Figure 5.113 shows how  $\Delta L$  and  $L$  add, giving a new angular momentum with direction that is inclined more toward the person than before. The axis of the wheel has thus moved perpendicular to the forces exerted on it, instead of in the expected direction.”

The Gyroscopic Effects: Vector Aspects of Angular Momentum website goes on: (This device is popular in demonstrations among physicists, because it does unexpected things.) With the wheel rotating as shown, its angular momentum is to the man’s left. Suppose the person holding the wheel tries to rotate it as in the figure. His natural expectation is that the wheel will rotate in the direction he pushes it—but what happens is quite different. The forces exerted create a torque that is horizontal toward the person, as shown in (Figure 5.113).

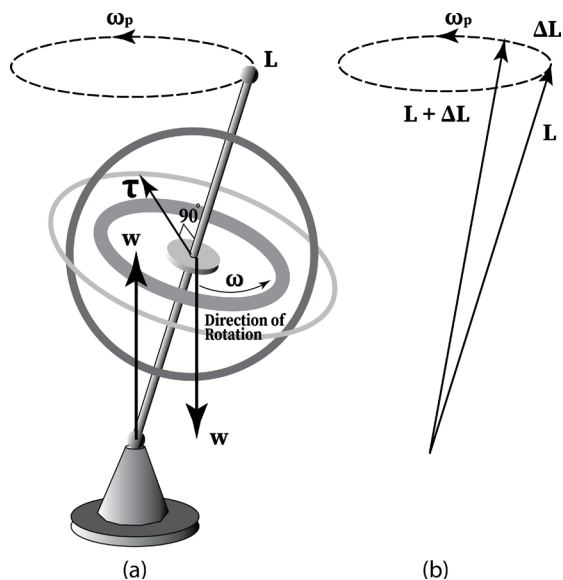

Credit: David de Hilster

**Figure 5.114** Two Forces Acting on a Spinning Gyroscope

*This same logic explains the behavior of gyroscopes. Figure 5.114 above shows the two forces acting on a spinning gyroscope.*

*"The torque produced is perpendicular to the angular momentum, thus the direction of the torque is changed, but not its magnitude. The gyroscope precesses around a vertical axis, since the torque is always horizontal and perpendicular to  $L$ . If the gyroscope is not spinning, it acquires angular momentum in the direction of the torque ( $L = \Delta L$ ), and it rotates around a horizontal axis, falling over just as we would expect."*

In all likelihood, the vast majority of non-scientific individuals will not be able to understand the above explanations, especially the reasoning given for the direction of the angular momentum. On the other hand, physicists should have no difficulty. Even so, in the author's opinion, it will still be difficult for most individuals to mentally visualize the three-dimensional physical mechanism as to exactly how precession occurs.

### 5.6.3 Second Description

The second description is from the website:

[http://www.schoolphysics.co.uk/age1619/Mechanics/ Rotation.](http://www.schoolphysics.co.uk/age1619/Mechanics/Rotation/)

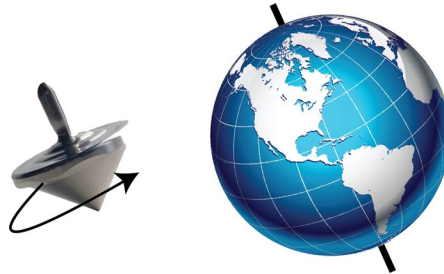

Credit: David de Hilster

**Figure 5.115** Precession of the Gyroscope and the Earth

See Figure 5.115 above. One of the most fascinating examples of the effects of angular momentum is in the precession of tops and gyroscopes. The phenomenon of precession is shown by all spinning objects if a torque is applied to the axis of rotation, even the planet Earth!

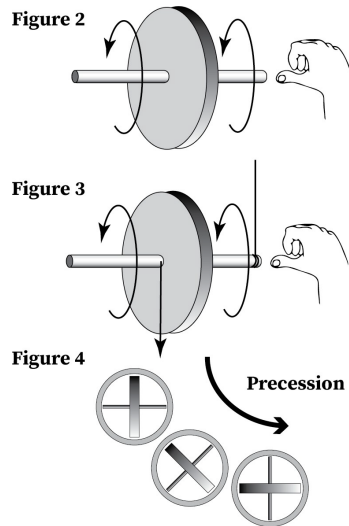

Credit: David de Hilster

**Figure 5.116** Direction of Angular Momentum

Before we can attempt to explain the way in which a gyroscope behaves, we must first realize that angular momentum, like linear momentum, is a vector. The way to work out the direction of this vector is shown in Figure 5.116 above.

”Imagine that the disc (D) is spinning in an anticlockwise direction about the axis A. The direction of the angular momentum of the spinning disc is found by considering a right hand gripping the axle with

the fingers curled round the axle in the direction of spin. The direction of the angular momentum vector is then in the direction in which the right thumb points.

"A string is now tied to one end of the axle, the axle is supported and then set spinning in an anticlockwise direction and the free end is then released (Figure 5.116, Figure 2). The weight ( $W$ ) of the gyroscope acts downwards as shown, and this causes a torque to act on the gyroscope in a direction out of the paper.

"This causes a change in the angular momentum about the vertical axis, and so the gyroscope rotates in an anticlockwise direction about this axis when viewed from above (see Figure 5.116, Figure 4). This rotation about the vertical axis is called precession. Notice that there is no change in the angular momentum in a vertical direction."

Vis-à-vis this second description, moreover, for both the novice and the physicists, the contents will most likely be able to be grasped. Nevertheless, again, the underlying three-dimensional physical principles as to just how precession transpires are still not fully apparent.

### 5.6.4 Third Description

This third description is written by the author, however, first a quotation or two with reference to inertia/momentum.

Newton's first law states:

"An object at rest will remain at rest unless acted on by an unbalanced force. An object in motion continues in motion with the same speed and in the same direction unless acted upon by an unbalanced force."

"Often called 'the law of inertia,' Newton's first law means that there is a natural tendency of objects to keep on doing what they're doing. Because all objects resist change in their state of motion, in the absence of an unbalanced force, an object in motion will maintain this state of motion." [Source: <http://teachertech.rice.edu/Participants/louviere/Newton/law1.html>]

The fundamental principle of a gyroscope is explained and illustrated below. Refer to Figure 5.117 and the following discussion.

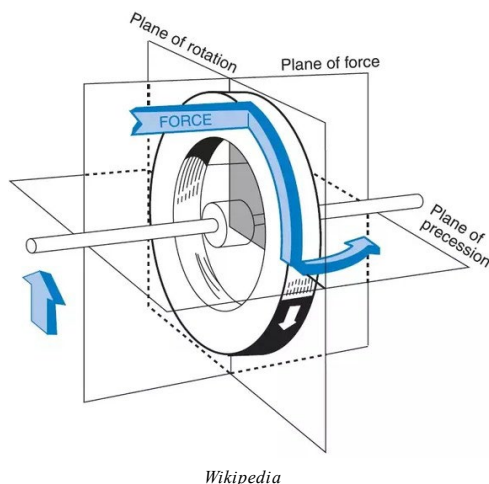

**Figure 5.117** Direction of Force as a Function of Falling [Fair Use]

<https://www.physicsclassroom.com/class/newtlaws/Lesson-1/Inertia-and-Mass>

As shown above, the direction of force as a function of "falling" is shown at the top of the gyroscope. The force then produces momentum in the same direction. However, because of the gyroscope's rotation,

*the force/momentum then shifts 90 degrees clockwise. This basic mechanism represents the underlying principle of precession, assuming it is applied over the entire 360 degrees of rotation.*

As depicted in Figure 5.117 above, the fundamental principle of the physics of a gyroscope is as shown. As one can observe, because of rotation and due to the conservation of momentum, the direction of force/momentum/torque (falling) shifts 90 degrees clockwise. This same principal is applied in 90-degree segments over 360 degrees of rotation.

At this time, the author poses this query. Regarding modern-day physics, concerning gyroscopic function, in addition to the conservation of momentum, are we not really observing with a change in rotational direction, a conservation of force (torque)? →This hypothesis will be clarified later on in this section←.

Now, as just imparted above, figures 5.120 through 5.123 below depict the same basic principle of physics but now in much greater detail. In addition, this basic function is broken down into separate 90-degree segments over 360 degrees of rotation. This segmentation makes it comparatively easy to visualize the underlying three-dimensional physical mechanism of precession.

### 5.6.5 The Author's Explanation of the Function of a Gyroscope

At this juncture, please view each of the figures as offered below.

Then read the following explanations, provided in the captions and following paragraphs.

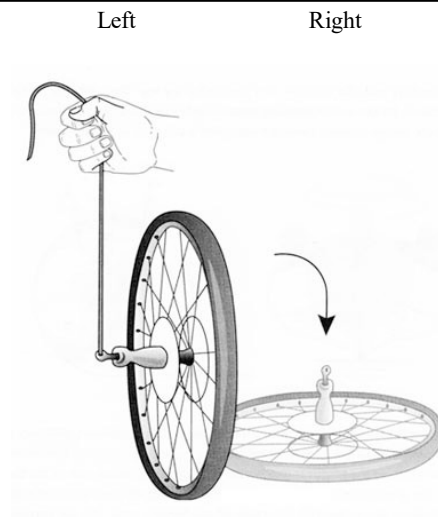

Wikimedia Commons

**Figure 5.118** Stationary Wheel Falls Over [Fair Use]

*The image on the left depicts a nonrotating wheel as initially positioned. Observe, under the influence of the gravitational field (in flow of space), it then "falls" to the Earth (torque) as revealed on the right.*

The following figures 5.119 through 5.123 were acquired from the website listed below, nevertheless, with some superimposed modifications made by the author.

<https://umdphysics.umd.edu/>



University of Maryland, Dept of Physics

**Figure 5.119** Spinning Wheel Maintains its Position [Fair Use]

Now, in contrast to Figure 5.118, if the wheel is rotating, then relative to the string, it remains in its original 90 degrees orientation as pictured above. The reasoning is revealed as explained in Figure 5.123. However, in order to comprehend that figure, one must first view and understand figures 5.120 through 5.122.

---



University of Maryland, Dept of Physics

**Figure 5.120** Starting Point 0 Degrees Rotation [Fair Use]

The wheel is rotating clockwise, and as the wheel attempts to "fall" towards Earth (torque), this action then produces two momentums/forces, furthermore, in the directions as shown above which are depicted by the two opposite-oriented black arrows. The torque does involve the pivot but for simplicity of explanation is not shown.

---



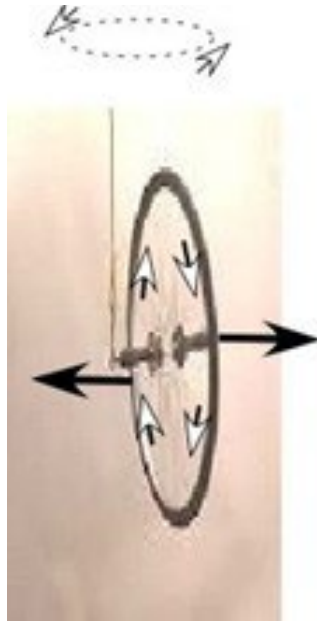

University of Maryland, Dept of Physics

**Figure 5.121** 90 Degrees of Rotation [Fair Use]

Next, as a function of 90 degrees of rotation, the orientations of the two forces/momentum "fall" presented in Figure 5.120 then change their directions, as shown in Figure 5.121.

This alteration of directions produces precession, because rather than the two forces/momentum/fall oriented vertically in opposite directions, they are now, at this time, pointed in the opposite directions horizontally.

The oblong circle, containing the two arrows, located at the top the Figure 5.121, symbolizes the function of precession. For purposes of orientation, the left arrow is directed out of the page whereas the right arrow is pointed into the page.



University of Maryland, Dept of Physics

**Figure 5.122** 180 Degrees of Rotation [Fair Use]

*Following that, at 180 degrees of rotation, the two directions of the forces/momentums/fall are then positioned as above. As a result, they counteract the two forces/momentums/fall depicted in Figure 5.120. This coupled counteraction maintains the right-angled position of the gyroscope relative to the string.*

Refer to Figure 5.123 below. If one takes the sum total of all the above forces/momentums demonstrated in figures 5.120 through 5.122, which do not counteract one another, then the remaining two forces/momentums/ (torque) produce precession (figures 5.121, 5.123, and 5.125). In addition, regarding figures 5.120 and 5.122, the counteracting forces/momentums maintain the gyroscope's right-angled orientation relative to the string as shown in Figure 5.119. And so, for that reason, it does not fall over as depicted in Figure 5.118.

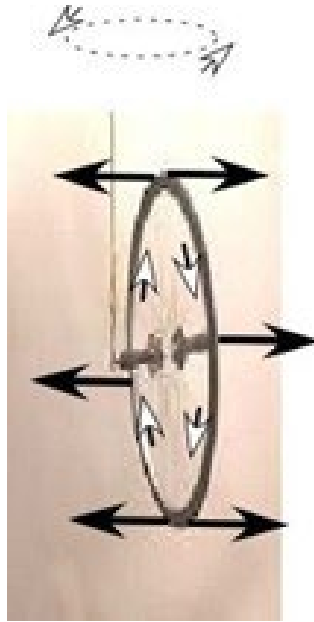

University of Maryland, Dept of Physics

**Figure 5.123** Wheel Does Not Fall [Fair Use]

*The right arrow of the oval is pointed into the page. The top and bottom forces/momentums counteract one another; therefore, the gyroscope maintains its right-angled orientation relative to the string. Alternatively, the side forces/momentums are heading in opposite horizontal directions, therefore, are unbalanced. For that reason, or more to the point, there is precession.*

### 5.6.6 The Author's Description of Two Experiments Relevant to Gyroscopes and Loss of Inertial Mass

The descriptions presented above explain the classic interpretation of the physics of a gyroscope. Nevertheless, it does not account for the loss of inertial mass, weight, or the elevating force as demonstrated by Laithwaite. So, at this time, let's return to potential experiments that confirm Eric Laithwaite's observations. These proposed experiments are basically an extension of his YouTube videos. Recall that when Laithwaite allowed the gyroscope to intrinsically precess on its own, it appeared to lose inertial mass or weight. In addition, when he forced motion in the direction the precession (forced precession), there was then a further lifting force exerted on the gyroscope. So as now presented below are two potential experiments relevant to Laithwaite theory.

Before proceeding, it should be noted that Eric Laithwaite has already performed the following two experiments, nevertheless, in a different form, so they are not new, moreover, already proven though not obvious on the YouTube videos. However, what now is different is this: The two tests described by the author can be performed at home or in any high school physics class. They are very simple. Again, his YouTube channel demonstrating his observations is given as below.

<https://www.youtube.com/watch?v=1eQp4grGdqY> See 20 min 51 sec.

An additional website related to these experiments can be found at:

<https://www.youtube.com/watch?v=NNLk5G3hgRg>

**Experiment 1.**

The experiment consists of a high-precision gyroscope (12,000 rpm), a central holder/stand, and a scale.

1. First, place the gyroscope and central holder on the scale.
2. Second, weigh the nonrotating gyroscope and holder/stander together.
3. Third, ramp up the gyroscope to 12,000 rpm; moreover, position its axis 90 degrees relative to the holder/stand, then let it precess.
4. Fourth, now during its precession, again weigh the gyroscope and holder/stand together.

**Experiment 2.**

The second experiment consists of a high-precision gyroscope (12,000 rpm), a central holder/stand, a turntable, and a scale.

1. First, place the gyroscope, turntable, and central holder/stand on the scale.
2. Second, weigh the nonfunctioning gyroscope, the holder/stand, and the nonfunctioning turntable all together.
3. Third, ramp up the gyroscope to 12,000 rpms, moreover, position its axis 90 degrees relative to the holder/stand.
4. Fourth, let the gyroscope precess. Again, weigh all of them together.
5. Fifth, activate the turntable in the direction of precession and, once again, weigh all three together.

**Regarding Experiment 1:**

It appears that during precession, the gyroscope loses some of its inertial mass.

- This explains why there is some reduction in measured weight (inertial mass).
- Additionally, it also is the reason why, when ongoing precession is blocked, there is then little or no force exerted upon the item that blocks it (reduced momentum = reduced inertia).
- Furthermore, it gives explanation for why, while the gyroscope precesses, there is little or no centrifugal force exerted on the stand/holder. In essence, for all of these phenomena to occur, there must be some reduction of the gyroscope's inertial mass.

What is more, in order to counteract the nonrotating portions of the gyroscope to prevent it from falling, there should also be a force, which maintains the gyroscope at a right angle relative to the string.

**Now, Referring to Experiment 2:**

In the scenario where there is forced precession in the direction of motion, there is an additional reduction in weight, moreover, the gyroscope's axis elevates. So in this situation, not only is there a further reduction in inertial mass, but there is now also a greater lifting force that elevates its axis from its original right-angle orientation (relative to the string). In other words, with forced precession, that force which maintains the nonrotating, and perhaps even rotating, portions of gyroscope (to prevent them from falling) at a right-angle increases, so the axis of the gyroscope then elevates. See Section 5.6.9, Page 272 for an alternative and somewhat contradictory theory/explanation concerning precession vs. forced precession.

The results of these two experiments cannot be explained by using modern-day theories. However, by employing PFGRT, the underlying cause and effect is clearly evident as clarified below.

So, if the ether exists, as virtually proved in Chapter 3, then everything in the universe is a function of that ether, including the workings of a gyroscope. Therefore, at this time, the author posits this alternative gyroscopic ether theory.

Before explaining how all this actually works, it will be helpful for the reader to review Chapter 2 (PFGRT), for only if one understands the concept the accelerating factor of the inflowing ether, can one then appreciate the above experiments and new theory.

For review, recall if an object, located far from a large astronomical structure, is accelerated by force, then the ether (space) resists the acceleration and so the object is compacted. This function is defined as inertia or inertial mass.

Conversely, if the inflow of ether accelerates the same object sited stationary on the Earth’s surface, moreover, the Earth blocks the object’s geodesic motion, then once again, it is compacted. This function is defined as gravity. Consequently, if the accelerations relative to the ether are equal, the compactions are identical. And so, gravity and inertia are equivalent.

Bear in mind that the **relative** acceleration of the object with compaction, **located specifically at the Earth’s surface**, moreover, as a function of the inflowing ether (acceleration factor), is then defined as its weight. This is how weight relates to gravity/inertial mass.

**5.6.7 Author’s Description Regarding the Loss of Inertial Mass**

At this point, let us now return to the function of a gyroscope. Given the PFGRT assumptions, as presented above, if one can reduce, or else counteract, the amount of the accelerating factor of the inflow of the ether (gravitational field) towards Earth, then for any affected object, gravity/gravitational field decreases. Consequently, its weight and apparent inertial mass also decrease. So how does a spinning gyroscope alter the inflow of the ether towards Earth?

This postulate is pictured below with respect to figures 5.126 and 5.127. But first, before proceeding, moreover, concerning **this specific gyroscopic example**, its physical structure, orientation, and function are portrayed in Figure 5.124, and explained in the following paragraphs.

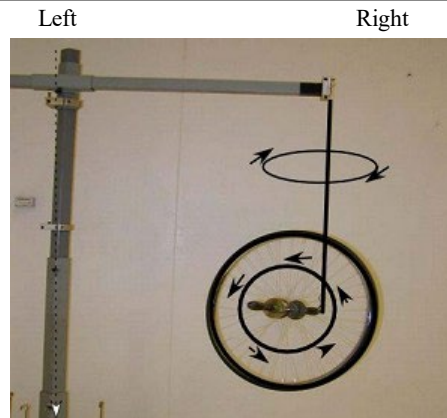

*StackExchange with Modification*

**Figure 5.124** Direction of Precession

For purposes of orientation, the central pivot is directed into the page. Additionally, the central pivot is attached to the rim by struts, the latter of which are not shown. The black arrows associated with the gyroscope represent the direction of rotation. The oblong oval with arrows portrays the direction of precession with the left arrow oriented into the page, whereas the right arrow is pointed out of the page. Furthermore, the picture presented in Figure 5.125 below is for the reader’s orientation. It displays a better perspective with the wheel spinning counterclockwise and precessing clockwise.

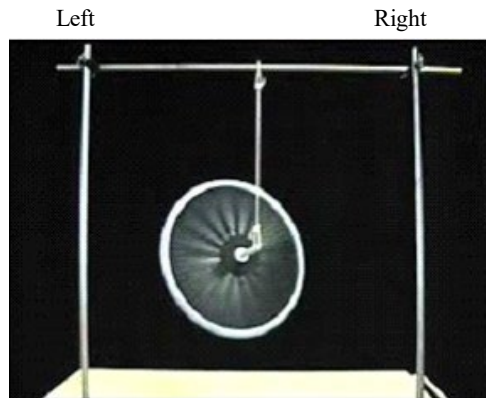

*Youtube.com MIT Department of Physics*

**Figure 5.125** Angle of Precession is Clear [Fair Use]

See Figure 5.126 below. The theory: The author posits that when the gyroscope disk's mass rotates, it then captures a portion of the linear inflowing ether, moreover, drags it into its own revolving motion as portrayed in Figure 5.126.

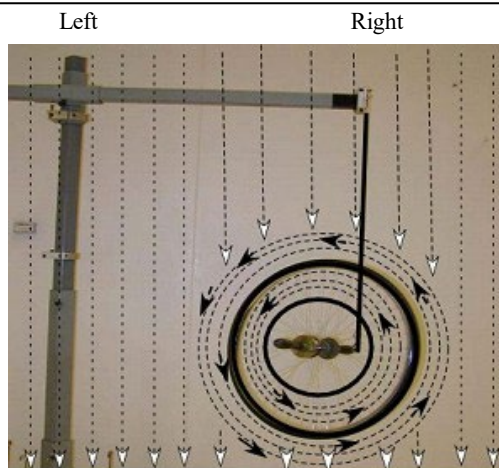

*StackExchange with Modification*

**Figure 5.126** Hollow Arrows Show Inflow of Ether [Fair Use]

The downward-oriented, dotted vertical-hollow arrows represent the inflow of the ether. A portion of the ether's linear inflow is captured, so it then revolves in synchrony along with the gyroscopic spin (circular solid arrows). Notice the captured spinning ether exists within the substance of the disk as well as outside.

As a result, when the gyroscope precesses, that portion of the captured spinning ether, on the side of the direction of precession (to the right) becomes compressed against the adjacent downward linear inflow as revealed below in Figure 5.127.

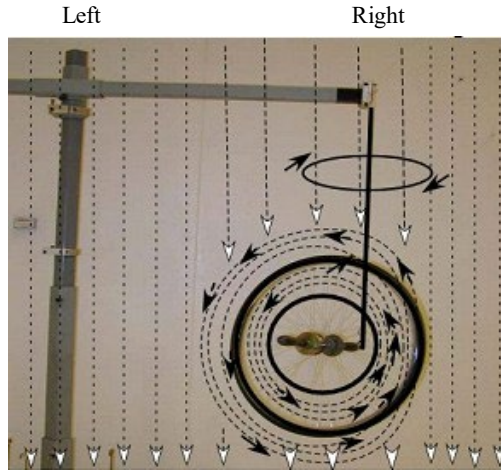

Stack Exchange with Modification

**Figure 5.127** Ether is then Compressed Against Right Side of Wheel [Fair Use]

*As a function of precession, the right side of the captured spinning ether is then compressed against the linear inflow on that same side, so it becomes denser compared to the left side. Observe that the spinning captured compressed ether on the right side is moving away from Earth, but on the left side, the noncompressed spinning ether is oriented towards Earth.*

Recollect the ether exists, not only surrounding the spinning gyroscopic disk but also within its own substance. Consequently, once again, on the side of the direction of precession, (right,) the spinning ether then becomes compressed, in essence, denser compared to the left. As a result, on the right, it crowds the downward linear inflow out. So, when comparing the two sides, there is less inflow (acceleration) towards Earth on the right as opposed to the left. For that reason, there is an overall reduction of the gyroscope's inertial mass or weight. It is also conceivable that there is a reduced inflow effect towards Earth because a portion of the inflow is captured, thus diverted, into a synchronous spinning motion along with rotating gyroscopic disk.

→More importantly←, on the right side, the captured, moreover, **compressed**, spinning ether accelerates the gyroscope's individual atoms upwards, in opposition to the ether's linear inflow (hollow arrows), the latter of which is directed towards the Earth. This as compared to the left side where the **noncompressed** spinning ether accelerates the gyroscope individual atoms towards Earth, in this case, along with the inflowing ether.

In effect, on the right, the upward **compressed** spinning ether, oriented in the direction away from Earth, has more acceleration effect upon the gyroscope's individual atoms compared to the left side, whereby the downward **noncompressed** spinning ether accelerates its atoms towards Earth.

All of the functions described above effect a reduction of the gyroscope's inertial mass/weight. This is Experiment 1. →This is crucial. Bearing in mind this model, the reduction of inertial mass/weight is **mainly** from a **net force** (compressed spinning ether) directed upon the gyroscope's individual atoms accelerating them upward and away from Earth←.

As for Experiment 2, this is the scenario where there is forced motion in the direction of precession (forced precession). Consequently, on the right, an additional compression occurs. For that reason, there is a further lifting force, exerted on the gyroscope's atoms.

This is because the now-increased, **compressed**, upwards-spinning ether further crowds out the downward-inflowing ether, moreover, further accelerates the individual atoms on the right side upwards, against the direction of the inflow. This is compared to the left side whereby the **noncompressed** converse function is oriented towards Earth.

Remember, the compression side (right) has more effect than the noncompression side (left), so overall the gyroscope's axis elevates. Concerning both experiments, only when the above orientational criteria are met does this effect occur. This is rationale for why when weighing a spinning gyroscope without precession, there is then no change of its weight or inertial mass. The outcome of reduced inertial mass only happens in the presence of precession (definitely with forced precession and perhaps/but not certain with nonforced precession).

### 5.6.8 Different Kinds of Experiments Versus the Loss of Inertial Mass

**In the author's opinion, even though not readily apparent, precession is a function of the gyroscope's "free fall" to Earth. Essentially, the motion of vertical free fall towards Earth rotates into horizontal precession (free fall).**

One cannot position the gyroscope in such a way that it cannot free fall, therefore, not precess, and still obtain reduced inertial mass/weight. Numerous experimenters have attempted to correlate a spinning gyroscope with reduced inertial mass/weight. Yet, if they do not let it free fall, thus precess (perhaps, with only forced precession; see below), they will fail to demonstrate a reduction in its inertial mass/weight.

In summary, the author believes that most or the vast majority, of experiments of this sort fail to let the gyroscope free fall or precess (perhaps again only forced precession). And for this reason, the experimenters are then unable to observe or measure reduced inertial mass.

As an aside, again assuming the gyroscope is in the upright position, there is no loss of weight/inertial mass (no precession). Consequently, in this scenario, where the axis of the gyroscope elevates, →from forced precession← **from a right angle relative to the string**, moving towards that upright position, there is then a balance between elevation from forced precession versus this counteracting second upright factor. As a result, the gyroscope's axis stabilizes at a given angle (< 90 degrees) relative to the string.

### 5.6.9 Precession Versus Forced Precession

It is evident that the reduction of weight or inertial mass is much more apparent with forced precession compared to intrinsic (nonforced) precession. The author acknowledges that numerous experiments have not demonstrated reduced inertial mass with pure precession alone. Alternately, the author posits forced precession will definitely produce a reduction of inertial mass/weight.

Now with reference to this concept, see the two YouTube videos offered below:

<https://www.youtube.com/watch?v=GeyDf4ooPdo> See 4:45 min

<https://www.dailymotion.com/video/x2ya0y4>

The first YouTube video is of intrinsic **nonforced** precession with the individual then providing a lifting force. Observe, the gyroscope does not lift by itself. The individual lifts it. The experiment demonstrated no loss of inertial mass or weight. But the lifting force performed by the individual should have caused increased weight during that particular lifting exercise. So, the loss of mass of the gyroscope and the lifting function exerted by the individual then counteracted one another resulting in no change of the weight measurements.

In the second YouTube video, whereby Laithwaite **forced the precession**, the test shows a definite loss of inertial mass or weight. Laithwaite did not lift the gyroscope; rather, the gyroscope elevated by itself during the interval of forced precession and then Laithwaite followed that motion.

This differential effect is not acknowledged in the above YouTube videos, so you will have to observe them and then make your own decision. In the author's opinion, forced precession demonstrates significantly more loss of weight (inertial mass) compared to intrinsic nonforced precession (the latter if at all).



### 5.6.10 Supporting Evidence for this New Theory/Postulate/Hypothesis

So what other evidence exists that supports the notion that this theory is correct?

First, during precession, if the gyroscope's movement is blocked, then the compression of the spinning ether in the direction of motion ceases. Consequently, the lifting force as a function of the upward compressed spinning ether also stops. As such, the gyroscope then immediately free falls towards Earth.

This outcome can be viewed at:

<https://www.youtube.com/watch?v=OpCEJO6V9g> See at 51 min 48 sec.

Second, if enforced motion, but in this scenario →against← the direction of precession, is initiated, then as a consequence, the compressed spinning ether is now located on side of the disk whereby it spins towards Earth. So instead of a lifting force directed away from Earth, which maintains the gyroscope at a right angle relative to the string, the force now generated is oriented towards Earth. For that reason, the gyroscope immediately free falls, moreover, is also further accelerated from an additional force directed towards Earth (downward force related to the spinning gyroscope plus the downward gravitational field force).

Again, this is what actually occurs as demonstrated in these videos.

<https://www.youtube.com/watch?v=OpCEJO6V9g> See at 4 minutes 45 sec to 6 minutes.

<https://www.youtube.com/watch?v=NNLk5G3hgRg> See at 33 sec.



<https://www.thestatesman.com/>

**Figure 5.128** Gyroscope Sited on a Slanted Wire, Slides Down that Wire [Fair Use]

Third, as pictured above, a spinning gyroscope sited on a slanted wire, slides down that wire. In addition, while in the process of sliding, it repeatedly rebalances itself. For instance, at different times, it may tilt to one side then to the other, but if so, it then uprights itself. A video of this example can also be viewed at:

<https://www.youtube.com/watch?v=NNLk5G3hgRg> See at 4 min 22 sec.

Interrelating this observation to the author's hypothesis; as the gyroscope slides down the wire, whenever it tilts to one side, it then begins to precess. As a result, the upward-oriented, captured compressed spinning ether, in the direction of precession, produces a lifting force, which then counteracts the original tilt. As such, it then uprights itself. Moreover, this same function occurs no matter which way the tilt. Therefore, as it slides down the wire, whenever it tilts back and forth, it always rebalances itself. Take note of this additional factor: while sliding down the wire, this downward action/motion also causes the gyroscope to assume an upright orientation.

### 5.6.11 Another Hypothesis Regarding Gyroscopes and Inertial Mass

Before evaluating this section, it might be prudent to read Appendix N, which uses numerous illustrations to explain the weak equivalence principal, inertia, inertial mass, ether, acceleration, and resistance

from the ether. In the author's opinion, for the average individual, diagrams elucidate these concepts much better, as portrayed in Appendix N, compared to a written description. Also, before proceeding, please review specific portions of Chapter 2 (see pages 36 to 46). While reviewing those pages, take note of the symbols IAA, IAR, LSA, as well as the terms "the velocity factor" and "acceleration factor" relevant to their definitions. One must understand the meaning of those symbols and terms before one can successfully evaluate the following attributes.

The section that follows is extremely abstract, so to help in comprehension, it will be explained by employing numerous and varied visual perceptions. Hopefully, this repetitive methodology described from different perspectives will ultimately aid the reader in grasping the complex concepts as now presented.

That which follows is somewhat lengthy but necessary in order to understand why gyroscopes lose inertial mass during precession. The writer posits another hypothesis relevant to the function of a gyroscope. However, in order to give explanation to this concept, first the following sixteen basic attributes are offered.

1. Recollect, as revealed previously in Chapter 2, that the inflowing ether frame possesses a  $\rightarrow$ velocity factor $\leftarrow$  as well as an  $\rightarrow$ acceleration factor $\leftarrow$ . The following assumptions refer to only the acceleration factor (IAA), which has two basic functions/aspects as defined below. Additionally, at least for now, in order to avoid confusion and to simplify the explanations, the velocity factor concept will be ignored and dealt with at another time and place (Appendix N).

2. The accelerating factor of the inflowing ether (IAA, aka free-fall ether frame), moreover, acting alone upon an object, consists of two separate aspects, which are distinct but still interconnect—the "falling force aspect" (dependent on atomic weight) (IAA\*) and the "acceleration aspect" (independent of atomic weight) (IAA\*\*).

3. Explained with more detail: When an object free falls/accelerates to Earth (acceleration aspect) (IAA\*\*) in geodesic motion, there is no resistance, therefore, no compaction, thus no inertial mass. Accordingly, all objects, including those of different atomic weights, accelerate/fall at the same rate. Discern that the rate of fall (acceleration) is identical for all objects regardless of atomic weight; it is independent of atomic weight.  $\rightarrow$ This is the weak equivalence principle $\leftarrow$ .

4. On the other hand, the falling force aspect (IAA\*), which produces a free-falling object, varies; it is dependent on atomic weight.

5. Assume the resistance from the ether, which is a function of the acceleration of objects, relative to itself (ether) by an outside force (e.g., rocket, LSA) is what produces inertial mass. So if there is no relative acceleration, there is no resistance = no inertial mass. And if there is no inertial mass/resistance, then the falling force aspect (IAA\*) will accelerate all objects equally, independent of their different atomic weights (**because there is no resistance/inertial mass**). Essentially, it becomes the acceleration aspect (IAA\*\*). Discern they are one and the same. This is how the falling force aspect (IAA\*) and the acceleration aspect (IAA\*\*) interconnect (IAA = IAA\* + IAA\*\*). For this reason, atoms of different atomic weights free fall at the same rate, but their falling forces will differ.

6. In summary, the acceleration aspect (IAA\*\*) exerted on falling objects is independent of atomic weight, so equal. Consequently, objects of different atomic weights, then free fall/accelerate at the same rate. Alternatively, the falling force aspect (IAA\*) vis-à-vis free-falling objects (geodesic motion) is dependent upon atomic weight, thus diverse—so the force of falling exerted on those objects varies as a function of atomic weight (IAA\*). Recognize if there is no inertial mass (resistance to the force), then the falling-force aspect (IAA\*) accelerates objects of different atomic weight equally. For this reason, the falling-force aspect (IAA\*) and the acceleration aspect (IAA\*\*) are the same thing—the weak equivalence principle.

The concepts, as just defined, refer to only the acceleration factor (IAA) and its two basic functions the falling force aspect (IAA\*) and the acceleration aspect (IAA\*\*). Alternatively, the following definitions explain how the resistance from the ether interrelates with the attributes as just presented.

1. The inertial mass of an object is not the intrinsic property of the object as classically assumed. Rather, it is the object's interaction with the ether, which produces that inertial mass. Both entities are required, the accelerating object ( $F = ma$ , LSA) and the responding resisting ether (IAR), in

opposite directions, resulting in compaction. And so, if there is no accelerated interaction with compaction/resistance, there is no inertial mass.

2. The inertial mass of an object is a function of its acceleration (e.g., rocket, LSA) relative to its own associated adjacent/internal ether, therefore inducing resistance from that frame (IAR) = compaction. Recall, the ether exists within the object as well as surrounding it, thus the term adjacent/internal.

3. If an object is at rest with the ether or at a velocity relative to the ether, then there is no accelerated interaction (compaction = no inertia/inertial mass). As such, the object is weightless in geodesic motion. In that setting, we assume the object possesses inertial mass. However, the only way to demonstrate/prove inertial mass is to accelerate it (LSA) with respect to its own accompanying adjacent/internal ether.

4. Essentially, if the object is in geodesic motion, there is no way to prove that it possesses inertial mass. So the author posits this basic assumption: →An object in geodesic motion does not possess inertial mass; for in that setting, there is no accelerated interaction with its own adjacent/internal ether. Again, for that object, if there is no compaction, there is no inertial mass←.

5. As a corollary, when an object free falls to Earth, from the acceleration factor of inflowing space (ether) (IAA = IAA\*\* + IAA\*) without opposing resistance = no inertial mass, it is weightless in geodesic motion. But most importantly, it is at rest with its own adjacent/internal-synchronized acceleration of the inflowing ether (free-fall ether frame). This last concept is very abstract, because the free-falling object is a product of the acceleration factor absent resistance (IAA = IAA\*\* + IAA\*). However, unless the object is further accelerated (e.g., rocket, LSA) with respect to its own free-fall ether frame, inertial mass cannot be proved or demonstrated.

6. This theory posits that when an object is at rest with the ether at a velocity relative to the ether, or at rest with its own adjacent/internal-synchronized, accelerating, inflowing ether (IAA), it then possesses no inertial mass (no compaction).

7. Only when an object is accelerated by an outside force, (e.g., rocket, LSA,  $F = ma$ ) relative to stationary ether, velocity of ether, or again relative to its own adjacent/internal-synchronized accelerating inflowing ether (IAA), all with responding ether resistance/compaction, does it then exhibit inertial mass. In all other settings, it manifests no inertial mass.

8. →In the simplest terms, the concept is this: Whenever an object is in geodesic motion (weightless), then at that time, in and of itself, it possesses no inertial mass←.

9. The inertial mass of an object is a function of its acceleration (or relative acceleration) applicable to its own adjacent/internal ether by an outside force ( $F = ma/LSA$ ), furthermore, with an opposing resistance generated from that ether frame (IAR) = compaction. Essentially, only as a product of compaction is inertia then present. On the other hand, it is not inversely related to the inflowing ether's individual atom acceleration (IAA) exerted upon the object without resistance, whereby there is no compaction. So, without the object's compaction, one cannot prove or demonstrate inertia or inertial mass.

10. To recap, imagine in your mind a free-falling object in geodesic motion. The object's motion is a product of both the acceleration aspect (IAA\*\*) and the falling force aspect (IAA\*), which are separate functions; nevertheless, they still interconnect (IAA = IAA\* + IAA\*\*). Accordingly, objects of dissimilar atomic weights free-fall equally; nevertheless, their falling forces differ dependent upon atomic weight. If there is no resistance (inertial mass), then the falling-force function (IAA\*) accelerates all objects equally, it transforms into the acceleration function (IAA\*\*). This is how the falling force function (IAA\*) and the acceleration function (IAA\*\*) interrelate (IAA = IAA\* + IAA\*\*). →In actuality, they are one in the same←. It is only when the free-falling object is further accelerated relative to its own already-accelerated frame, free-falling ether frame (IAA), such as from rocket (LSA,  $F = ma$ ), that the resistance from the ether then emerges. So at that time, the object becomes compacted/inertial mass.

So let us now apply these principles to our FW example.

Again, recall the Ferris wheel (FW) illustration as presented earlier in this chapter, →which assumes no friction←, moreover, continuous/continuous rotational motion (centripetal acceleration) devoid of energy input. See Section 5.2.4, especially pages 181 and 182. With reference to that specific example, the author experienced compression while moving away from Earth but weightlessness traveling towards Earth. Notice, inertia (compaction) only occurs while moving in the direction from Earth; nevertheless, the compression effect does not alter the rate of rotation (FW).

The reasoning behind this is: On the left side, the direction of rotation of the FW is oriented along with the linear inflowing ether frame (IAA). →This function is →somewhat similar← to the free-falling motion of an object or its geodesic motion, moreover without resistance = independent of atomic weight = no inertial mass (IAA\*\*)←.

Alternatively, while moving from Earth (right side of FW), the inflowing ether frame (IAA), now in the opposite direction of rotation, is precisely equal to the left side (FW); however, at this time, there is compaction partially a function of atomic weight. Remember, on the right side, the FW's rotational motion is oriented against the inflowing ether frame. →This second function is →somewhat analogous← to an object's acceleration from force (LSA) relative/against the inflowing ether frame with its associated opposing resistance = dependent on atomic weight = compaction = inertial mass/inertia (IAR)←.

Keep in mind, the radial centripetal acceleration force remains constant, so the FW continues to rotate without change, even in the face of compaction (inertia) on the right side.

With respect to our FW scenario, the most crucial concept to take home and remember is this: The force derived from the same linear inflowing ether frame (e.g., gravitation field) is equal and symmetrical on both sides (FW); even so, the author's experience of compaction/inertia produced only on the right side had no effect on the FW's rotational rate.

Please pay attention to these last two paragraphs; at the end, a fundamental question is posed. Finally, one last time, this FW model presumes, but now expressed in layman's terms, that the linear downward force produced by the gravitational field is equal and symmetrical with respect to both sides of the FW. As a result, there is no initiation or alteration of rotation induced by gravity (assume no friction). All the same, upon commencement of rotation, if not already rotating from an outside torque, counterclockwise, there is compression/compaction present only on the right side (FW). Yet, this compaction effect does not alter the Ferris wheel's rate of rotation (radial centripetal acceleration/tangential angular velocity). Think about this fact/observation very carefully. Both linear inertia (compression) and its corollary linear momentum (compression) are associated with a change in linear/translational velocity, increased or decreased—not so in this scenario. Nor does the compaction effect on the right result in a change in the radial acceleration/tangential angular velocity of the FW.

So, here is the fundamental question. How does one explain this FW example as just presented with the use of modern-day classic physics? For the average individual, this hypothesis/question is most likely very confusing. For mainstream science, it is probably a conundrum in which if there is no answer; then it requires an entirely new physics. Again, to all physicists/scientists, answer this basic inquiry: →By what means can you explain this FW example/model by using the classic excepted/standard laws of physics?← If you can't, there must be another solution. That answer is given below.

### **In summary, a new physics?**

- Our concepts of inertia and inertial mass all involve compaction/compression.
- Force is distinct from inertia. Force exerted on an object can occur independent of inertia (resistance with compaction) such as a free-falling object = no inertial mass/no compaction.
- This theory posits that when an object is at rest with the ether, at a velocity relative to the ether, or else at rest with its own adjacent/internal synchronized-acceleration of the inflowing ether, it then possesses no inertial mass (no compaction).
- Only when an object is accelerated (e.g., rocket-LSA) relative to stationary ether, velocity of ether, or again, with respect to its own adjacent/internal synchronized-acceleration of the inflowing ether all with compaction, does it then exhibit inertial mass. In all other settings, it manifests no inertial mass.
- →In the simplest terms, the concept is this: Whenever an object is in geodesic motion (weightless), then at that time, in and of itself, it possesses no inertial mass←.
- The inflowing ether frame (IAA) has a velocity factor as well as an acceleration factor. The following assumption refers to only the acceleration factor. The accelerating factor of the inflowing ether (IAA), moreover, acting alone upon an object, possess two separate functions which are distinct; even so still interrelate →the falling force aspect (dependent on atomic weight) (IAA\*) and the acceleration aspect (independent of atomic weight). (IAA\*\*)←. And if there is no resistance to the falling force aspect (inertia), it becomes the acceleration aspect—they are one and the same.

- Given the assumption as just presented, then picture a free-falling object in geodesic motion. The object's motion is a product of both the acceleration aspect (IAA\*\*) and the falling force aspect (IAA\*), which are divergent. Nevertheless, they still interconnect with one another. As a result, objects of different atomic weights free fall at same rate but their falling forces differ, the latter dependent upon atomic weight.

- Inertia is a product of the resistance from **only** the ether (IAR) exerted on an object being accelerated by an outside force, such as a rocket (LSA). Furthermore, the amount of resistance is a function of the change in the object's velocity or relative velocity (acceleration relative to the ether), as well as its atomic weight.

- →Another way of perceiving all of this now expressed in a more vernacular form is: The accelerating factor of the inflowing ether (IAA) acts upon each separate atom within the object individually without compaction (no inertia). Consequently, there is symmetry between the acceleration of the ether and the accelerated motion of the objects. On the other hand, whenever this combined synchronized motion is disturbed/changed from an outside force ( $F = ma = \text{rocket} = \text{LSA}$ ), not part of the ether, then this very same ether resists that change (again acting upon individual atoms), resulting in compaction (inertia)←.

- As a partial analogy (and the author emphasizes partial), the flow of a river will carry with its own motion a heavy metal boat, a light wooden canoe, and a feather equally (in synchrony), even considering their different atomic weights and sizes (somewhat comparable to the weak equivalence principle). Subsequently, with respect to this combined synchronized uniform flow, if the motion of only those objects is equally obstructed by a fixed structure but not the movement of the river, then from those objects there will be different amounts of force (momentum/inertia) exerted on that blocking structure. Recognize that the drift of the river is to some degree analogous to the inflowing ether frame (IAA), and the fixed structure is somewhat similar to acceleration (deceleration) of those three objects by an outside force ( $F = ma$ , rocket, LSA) relative to that flowing frame (the synchronized motion of the objects and the flowing river)—resulting in compaction of the objects.

- Finally linear acceleration and rotational centripetal accelerations are two separate independent functions, perhaps not associated with the same laws of physics. This is why Laithwaite's experiments/demonstrations relevant to gyroscopic function, combining both functions in the real world are so confusing, at least on the surface, not compatible with all of Newtonian physics.

As an aside, scientists have successfully floated a frog in a very strong magnetic field. Therefore, in this case, the accelerating factor of inflowing space (IAA) acts on each individual atom within the frog directed towards Earth and the magnetic field acts on each individual atom within the frog away from Earth, so no compaction. Now, here is the key question: Does the entire apparatus weigh the same with the frog floating versus with frog not floating. If it weighs less, this experiment is a potential validation of this compaction/inertia/inertial mass hypothesis.

See <https://www.youtube.com/watch?v=2VIW0nYfN3A>

The attributes, as just presented, will now be used to construct a theory, which gives explanation to the reason why, when a gyroscope precesses, it loses some of its inertial mass. There are two basic premises.

**Premise 1.** Recall as explained earlier in this chapter, when the gyroscope's disk rotates, it captures a portion of the linear inflowing ether, moreover, drags it into its own spinning motion as depicted in Figure 5.126. For that reason, the angular acceleration of the atoms of the spinning disk are then in synchrony with respect to its own adjacent/internal captured, angular, accelerating spinning ether. So, relative to each other, they are at rest.

Accordingly, with reference to →only the spinning disk←, there is no inertial mass generated, since overall, there is no relative acceleration of its atoms compared to its associated captured spinning ether.

**Premise 2.** Now, whenever a gyroscope rotates, moreover, precesses, even though not readily apparent to the casual observer, it is, in fact, →free falling towards Earth in geodesic motion←. Therefore, as posited earlier, it exhibits reduced inertial mass.

As a result of these two premises, moreover, with reference to this specific right-angle orientation, a gyroscope, while undergoing precession, possesses reduced inertial mass. This explains the reason why

when a gyroscope's ongoing precession is blocked, there is then no momentum/inertia exerted upon the item that blocks it.

Whenever precession is obstructed, the gyroscope rather than undergoing precession, which is a form of free falling, then resumes classic defined free fall, but at this time, directed towards Earth. This is because at the instance of obstruction, there is then no compression of the upward captured spinning ether. Recollect, precession is what produces the lifting force that maintains the gyroscope's right-angle orientation relative to its string. So, when this function terminates, the gyroscope then reorients its motion from precession (a form of free fall) to classic free-fall acceleration towards the Earth.

The author also posits one other alternative hypothesis regarding decreased momentum exerted upon an object that prevents ongoing precession. So, as a second possibility and only an option, the reduced momentum effect may be a partial function of whenever ongoing precession is blocked—the gyroscope's geodesic motion immediately changes direction. In other words, precession (a form of free fall) rather than being directed at the item, which prevents it, then ceases; moreover, immediately it begins to naturally free fall towards Earth. Essentially, this almost →instantaneous reorientation← of two forms of geodesic motions is perceived as decreased momentum exerted upon the item, which inhibits ongoing precession. In addition, the perceived loss of inertial mass also explains why during precession, there is a reduced centrifugal force exerted on the gyroscopic holder. This observation is evidenced at:

*<https://www.youtube.com/watch?v=OpCEJO6V9g>. (See at 19 minutes 51 sec.)*

### 5.6.12 Gyroscopes as a Partial Function of Force

If the reader will recall, earlier in this chapter, the author posed a question: Is gyroscopic precession a function of momentum or force? The author believes it is partly from force, and here are some reasons why.

- Whenever a gyroscope precesses, it actually is free falling toward Earth, moreover, in geodesic motion. This free-fall motion (precession) is a function of **force** derived from the accelerating factor of the inflowing ether.

- Precession is the product of a torque, two **forces** pointed in opposite directions. In effect, a torque represents coupled **forces**. Precession is actually the function of the vertical free fall of the gyroscope from a gravitational **force**, however, now shifted 90 degrees horizontally but with **reduced inertial mass**, as already explained.

- In addition, while undergoing precession at a right angle, whenever mass/weight is added (**force**) to the nonrotating portions of the gyroscope, the precession rate increases. Again, precession is a coupled force (torque). So, if the **force** of free fall is increased due to added weight, then the coupled forces of precession with a **reduced inertial mass** also rise proportionally. As a result, the precession rate increases, consequently inducing an added upward force, which then counteracts the added weight.

- Not all parts of a gyroscope lose inertial mass, so relative to the string, in order to maintain the nonrotating portion of the gyroscope at a right angle, a counteracting force must be present thus preventing the gyroscope's movement to Earth.

- In summary, the precession of a gyroscope superficially appears to be a function of inertia or momentum, but in actuality, it involves mainly force. Presupposing that predominantly, force is involved, the author posits the following logic.

- Assuming a closed system, furthermore, involving only momentum/inertia, one cannot propel that closed system.

- Alternatively, as described earlier in this book, again pertaining to a closed system, by using force, one can propel that closed system. See Chapter 5 (railguns/box).

- Therefore, by using multiple gyroscopes, it should be possible to construct a spacecraft (closed system) which can self-propel devoid of a propellant.

- The topic of gyroscopic propulsion will be dealt with later on in this section. However, the point of logic is this: If the precession of a gyroscope involves force, then multiple gyroscopes can be utilized to self-propel a closed system without a propellant (spacecraft).

See website: *<https://ok.ru/video/90762578558>*

**5.6.13 Further Discussion Regarding Inertial Mass**

Regarding inertial mass, this new novel hypothesis leads to a conflict with Chapter 4’s theory of the origin of inertial mass. By logic then, one or the other may be an erratum or even both. So to resolve this dilemma, the author posits this potential hypothesis. The methodology for explanation is as follows:

1. First, the original concept of inertial mass as proposed in Chapter 4 is represented.
2. Second, the new theory regarding inertial mass of Chapter 5 will again be discussed.
3. Third, Chapter 4’s theory on inertial mass will be subsequently modified, so it is then compatible with this new alternative premise of Chapter 5.

**First**, recall and review: When an electron (field) possesses an increased velocity relative to the ether of PFSRT, its velocity magnetic field (VMF) then also increases. In addition, as the electron’s velocity increases linearly, the velocity magnetic field increases by a Lorentz transformation function (LTF). →**The velocity magnetic field represents its relativistic inertial mass**←.

Now, generally, although not exclusively, electrons are not solitary entities; rather, they orbit a nucleus. Thus, while in orbit, they possess a velocity relative to the ether of PFSRT. As a result, a magnetic field forms. This is not their intrinsic revolving (spin) magnetic field (SMF), rather their orbital velocity magnetic field (VMF). And so, assuming an atom is overall at rest with the PFSRT, its orbiting electrons are not. (See Figure 5.129 below.) As a result, the electrons produce (VMFs).

If you think about it, the overall rest inertial mass of an atom is actually a function of the relativistic inertial masses (VMF) of all its rapidly orbiting subatomic entities. This is because as they orbit, they all travel at a high velocity relative to the PFSRT. And as a result, they possess relativistic inertial masses. The total sum of all those subatomic relativistic masses is the rest inertial mass of the atom.

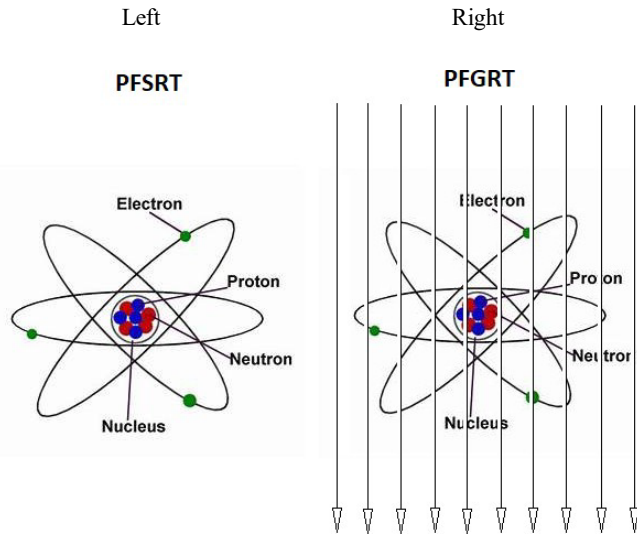

Wikipedia

**Figure 5.129** Relativistic Mass is the Rest Inertial Mass of the Atom [Fair Use]  
 Left = Rest Mass; Right = Relativistic Mass

- The figure and discussions above and below focus initially on the electron. However, in the following paragraphs, the ideas presented for the electron will then be broadened to encompass all of the atom’s subatomic units.
- On the left, by definition, the overall atom is at rest with the ether (PFSRT); nevertheless, its orbiting electrons are not. For that reason, the velocity of each electron, relative to the ether of PFSRT, is equal to its own orbital velocity around the nucleus. Consequently, they all then possess relativistic inertial mass.

Therefore, the sum total of the relativistic masses of all the electrons is the  $\rightarrow$ **rest inertial mass** $\leftarrow$  of the atom.

- On the right, the overall atom possesses a velocity relative to the inflowing ether (PFGRT) as symbolized by the downward vertical dotted arrows. In this setting, the velocity of each electron relative to the ether is equal its own orbital velocity around the nucleus plus the velocity of the inflowing ether. In this scenario, the sum total of all the relativistic masses of all the electrons is now the  $\rightarrow$ **relativistic inertial mass** $\leftarrow$  of the atom. The same effect holds true when an atom possesses a velocity relative to the ether PFSRT.

- The above description involves only electrons, which cannot account for the total inertial rest mass of the atom. So now let's broaden the concept. Within the internal structure of atom, all of the subatomic units (fields) in one form or another are in orbit, including quarks (protons neutrons—all fields). As for the later [nucleus], they all revolve around one another relative to a theoretical physical center-point—there is no particle, only revolving fields. Therefore, they all possess a velocity with respect to the ether of PFSRT/PFGRT.

Consequently, regarding these entities, moreover, as a function of the orbital velocities, they produce relativistic inertial masses, analogous to the electron model just presented.

- In the case whereby the overall atom is at rest with the PFSRT, the sum total of all the subatomic VMFs produces, for that atom, its rest inertial mass as shown on the left side of Figure 5.129. Basically, the sum total of the relativistic masses produced by all the orbiting subatomic entities is the rest inertial mass of that atom.

- Alternatively, if the overall atom possesses a velocity with respect to the PFSRT/PFGRT, then the VMFs produced by all the orbiting subatomic entities is now the atom's relativistic inertial mass as shown on the right of Figure 5.129.

- Notice, the relativistic inertial mass is greater than the rest inertial mass, because, regarding the former, all the subatomic entities overall possess a greater velocity relative to the ether.

---

**Second**, the inertia of the overall atom only manifests itself if it is accelerated relative to its associated ether with compaction. Inertial mass requires an ether, moreover, acceleration of an object with respect to that adjacent/internal ether. This concept is not so simple. This acceleration of the atom by an outside force (e.g., rocket) manifesting inertia is—relative to stationary ether, relative to a velocity of the ether, as well as relative to synchronized adjacent internal accelerating ether (e.g., additional acceleration relative to a falling object in geodesic motion as a function of a gravitational field). Alternatively, when an object exists in the state of geodesic motion, it does not possess inertial mass, because in that setting, there is no relative acceleration with respect to the ether and the resulting compaction.

**Third**, referring to the first theory of Chapter 4, regarding an atom at rest with the PFSRT, all the subatomic orbiting entities summed together possess no specific direction, because as they orbit, they directionally counteract one another. Alternately, with reference to the second theory of Chapter 5, because the atom possesses an overall accelerated direction through the ether, there is then also an overall direction relative to the sum of all its subatomic units (VMFs). Therefore, inertia is not only a function of acceleration relative to the ether, but it also has, relative to an overall atom, a directional component as well. The author admits this is a speculative theory.

## 5.6.14 Propulsion Using Gyroscopes

In practical terms, what does this gyroscopic presentation signify? It means one can utilize the ether to produce propulsion, somewhat analogous to how one tacks against the wind with a sailboat.

A hypothetical propulsion device based on this concept is now offered. To start with, please review the Eric Laithwaite video:

<https://www.youtube.com/watch?v=OpCEJxO6V9g> See 44 min 40 sec.

In the video, Laithwaite reveals a specific function associated with a gyroscope. Although not acknowledged in the video, that particular principle can be used to propel a spacecraft. The structure and function of Laithwaite's experiment is presented below.



1. The experiment, in part, consists of a gyroscope fixed and with its axis longitudinally fastened to a pole.
2. The other end of the pole is attached to a central stand containing a holder, in such a way that gyroscope/pole combination (GPC) is able to free fall towards Earth. The holder also allows the gyroscope/pole to circle around at a right angle.
3. At the location of the holder, there is a spring, which gauges the weight of the (GPC) by moving up or down.
4. The gyroscope is then ramped up, moreover, allowed to self-precess at a right angle relative to the stand (holder).
5. As such, the GPC circles around the central stand, moreover, without producing a significant centrifugal force.
6. Furthermore, in the scenario where there is forced motion of the GPC in the direction of precession, the GPC axis then rises. At the same time, the spring indicates the GPC has lost weight (forced precession).
7. Therefore, forced rotation in the direction of precession must have produced an upward lifting force on the GPC.

The above account is the physical structure, moreover, functionality of Laithwaite's experiment as demonstrated on the web video. So, at this point, let us rearrange, furthermore, expand this model to hypothetically produce a spacecraft, which self-propels without a propellant.

To start, imagine, instead of only one GPC, envision now there are four identical ones. In addition, picture in your mind that they are all symmetrically organized in a circular plane around the central holder, moreover, at a right angle. An important concept to recognize is this: Each CPC is attached to the same central holder, moreover, allowed to free fall towards Earth. Essentially, it must free fall in order to function properly.

Next, picture that all four gyroscopes are ramped up in the same rotational direction and at precisely the same angular velocity. They are then allowed to self-precess. After that, envision, analogous to Laithwaite's experiment, that forced motion of the entire planar structure is initiated in the direction of precession.

Presuming the Laithwaite experiment is legitimate, and with reference to the plane of the structure, the combined  $\rightarrow$ net $\leftarrow$  central vector force produced by all four gyroscopes as a function of forced precessional motion is in the upward direction oriented directly away from Earth.

After that, visualize that on the underside of this apparatus, relative to its plane, moreover, along the axis of the central holder, a mirror image structure is assembled, in such a way that that all four of these second set of gyroscopes can still free fall towards Earth, similar to the top half. So relative to both halves, all gyroscopes can free fall to Earth.

Furthermore, conceptualize at the location of the central holder, that both planar halves are attached to each other, nevertheless, allowed to rotate independently, relative to each other. As a result, the top planar structure can rotate in one direction, whereas the bottom assembly can rotate in the opposite direction.

Now, with respect to the top half, assume the precession is oriented in one direction, whereas the bottom half is equally oriented in the opposite direction. What is more, pertaining to each side, presume equal forced motion/precession is initiated in the same direction as the gyroscopic precession on that side.

Given all of the above, moreover, in association Laithwaite's demonstration, if one observes the  $\rightarrow$ net forces $\leftarrow$  generated by all eight gyroscopes, they are all in the same upward direction away from Earth. As a result, this device can be used as a model for the construction of a spacecraft, which can self-propel without a propellant.

Listed here are YouTube channels demonstrating some of the principles involved.

<https://www.youtube.com/watch?v=BeO91URF7dM>

[https://www.youtube.com/watch?v=Taj4VAiL\\_vw](https://www.youtube.com/watch?v=Taj4VAiL_vw)

<https://www.youtube.com/watch?v=MmtOAfrGnw0>

### 5.6.15 Propulsion with Magnetic Fields

As previously elucidated (Chapter 4), inertial mass is a function of magnetic fields (VMF). Within an object, the greater the summation of the opposing magnetic fields (VMF), the greater is its inertial mass.

Recall in theory, a solitary electron at rest with PFSRT possesses no VMF, therefore, it possesses no inertial mass. And an electron at  $c$ , with respect to the PFSRT, possesses an infinite VMF, so an infinite relativistic inertial mass. You can now picture in your mind the rationale for why matter, including the electron, cannot be accelerated faster than the speed of light.

Therefore, if one can manipulate/diminish or change all of an object's internal magnetic fields (VMF is the inertial mass of the object), one should then also be able to markedly reduce its inertial mass. But most importantly, at the same time, by using other magnetic fields, propel that object devoid of a propellant, then this would be another form of spacecraft. All of this has been described in prior sections of the chapter.

In addition, reducing the VMF would enable the object to exceed the speed of light (and avoid time dilation). The explanation is as follows.

The limiting factor for an object not exceeding the speed of light is its infinite relativistic inertial mass as a function of the resistance from the ether, which in turn is a function of the VMF. So, if there is no inertial mass (VMF), then there is no barrier to exceeding the speed of light. Consequently, if one can eliminate the VMF (inertial mass) of an object, one can also accelerate that object to a velocity faster than the speed of light.

This reflection leads to the taboo subject of UFOs. For most of recorded history, numerous individuals have reported flying craft defying the present-day assumed laws of physics. Additionally, many of these individuals were/are extremely reliable. Moreover, there have been so many of them, that it is unreasonable to assume that all their stories are fabrications. Furthermore, is it rational to presume that we on Earth are the only intelligent beings in the universe? I think not. What is more, we now know that most stars possess planets; there must be trillions of them. Some must be inhabitable. Given all this then, it is not irrational to propose that some UFOs represent spacecraft from alien civilizations. →In other words, there are others←.

Assuming all of this is apropos. Moreover, considering the observed physical behavior of UFOs, our present-day concepts of the physics of the universe is in erratum. There must be a totally unrecognized physics, since 50-ton UFOs accelerate in a flash, execute 90-degree turns with extreme velocity, emit EMP, moreover, travel in space (ether) without an apparent propellant. Essentially UFO's appear to exhibit no inertial mass.

So again, if inertial mass is partially a function the magnetic field (VMF), as proposed by this book, then if one manipulates that field (VMF) by a pulsed magnetic field and reduces an object's/spacecraft's inertial mass while propelling it at the same time, then one could build a superluminal functioning craft without a propellant. Fundamentally, a pulsed magnetic field could be used to neutralize the VMF (inertial mass) and simultaneously propel the craft. **This functionality is similar to what is observed with UFOs.**

It is the author's opinion, that some form of combination of the ideas presented within this publication can be utilized to construct, power, and propel such spacecraft by utilizing magnetic fields and the ether. If so, then we as a species (grandchildren) are eventually going to travel to the stars. We shall see how the future unfolds.

## 5.7 Conclusion

Einstein's SRT/GRT unlike QM are mathematical theories with some highly significant concepts, although some but overall, very little everyday useful value. Alternatively, considering the ideas/experiments/theories presented within this article, PFSRT and PFGRT are highly practical theories, furthermore, most likely eventually profitable. As such, given sufficient time, it is the author's opinion this pragmatism will give impetus to overturn relativity.

In addition, the majority of, although not all of, the concepts presented in this book are not original. What the author has done is to assemble disparate concepts postulated by many others into one comprehensible visual form, without the use of mathematics. The author, as in his actual profession, is more

of an assembler of images rather than an originator. Most ideas, but not all, presented within this writing were found while surfing the internet over the last ten years, moreover, not obtained from scientific journals. However, adequate records were not kept, so there are no typical references/bibliography. Nevertheless, some of the major concepts were obtained by attending the Natural Philosophy Alliance (NPA) conferences and also derived from Henry Linder's Flowing Space articles as listed below.

*<http://henrylindner.net/Writings/BeyondNewtonPE.pdf>*

*<http://home.epix.net/hhlindner/Writings/Space/Physics.html>*

*<http://henrylindner.net/Writings/PhysessImplications.pdf>*

Furthermore, this author gives permission for anyone to use and publish this book in any manner that he or she so chooses, even for profit, with the exception of any figure labeled as copyrighted/fair use or any quotation. What is more, at least for now, this author also wishes to remain anonymous. There are minor reasons, such as resistance from mainstream physicists to new ideas from a novice, who is not part of their hierarchy, resistance from industry related to new inventions that destroy profits, resistance from the military in order to sequester for advantage, and finally, and most importantly, resistance from the true hidden deep state governments in order to maintain the central control mechanisms over their populations.

But the major reason for remaining anonymous is encoded in the letters as follows (A g f t L. U i i p f m, a o m)—as for now, this encrypted message will remain concealed until, moreover, if this book's theories ever come to light. If true, compared to what these initials represent, then all that lies herein within this book then shrinks to insignificance.

Now, presuming the theories presented in this article are valid, furthermore, derived inventions come to fruition, then in the author's opinion, this will result in a paradigm shift relative to all of human history. But as always with great change, there is enormous conflict as diverse factions vie to keep or obtain new wealth and power. And so, before the dawn of a new era, comes the night.

And finally, everything originates from the ether, except the ether itself. Given that, then consider this. If the concepts presented in this book are correct, what is more, ideas by which the average individual can comprehend, then perhaps, it is the Lord's plan that not just a select few, rather the vast majority of us, his children, know, understand, and appreciate **The Ether**.

By Anonymous (Ramsey) and edited by Rowena Stevens. This book is dedicated to, inspired by, and abetted by the Lord/Creator.

The author expresses grateful appreciation to Rowena Stevens and Robert de Hilster for editing this book. The author also appreciates the input/involvement of Cynthia Whitney PhD, Deiter Brill PhD, Greg Volk PhD, Phillip Mann PhD, Henry Linder, David de Hilster, Laura Orsini, and David Pepion.